

# In The Language of Flowers: A 21st Century Approach to Floriography

“Flowers and humans have always had an intrinsic emotive relationship. Cultivated and bred to accomodate our needs and desires, sometimes for commerce, but always for beauty...Flowers have been used symbollically throughtout history...from declarations of love to conveyance of remorse, and ultimately as literal signs of spring and regeneration”

- Alex McLeod for his exhibition, “Necroflora”

“A garden is a nursery for nurturing connection, the soil for cultivation of practical reverence. And its power goes far beyond the garden gate—once you develop a relationship with a little patch of earth, it becomes a seed itself...It’s a place where if you can’t say “I love you” out loud, you can say it in seeds. And the land will reciprocate, in beans.”

- Robin Wall Kimmerer, Braiding Sweetgrass



## Contents

- I. Introduction
- II. Site Analysis  
Franklin Delano Roosevelt Park
- III. Modules  
Ikebana Study  
Modules
- IV. Site Plan  
Overview  
Organization
- V. Exhibtion Visualizations





# Floriography

“In the Language of Flowers,” investigates the practice of Floriography (the Victorian language of flowers) as a response to the past year of contending with the global pandemic social crises. This moment has forced us to rethink the ways in which we communicate with each other. The exhibition expands the scope of Floriography beyond western influences and looks at floral meanings in different cultural contexts. It also acknowledges how the characteristics of flowers— such as their color, growing patterns, and medicinal properties— can provide additional meaning. Visitors will be given a re-imagined dictionary to help guide them through the exhibition and learn how to create floral messages.



Pages from an original Floriography Dictionary

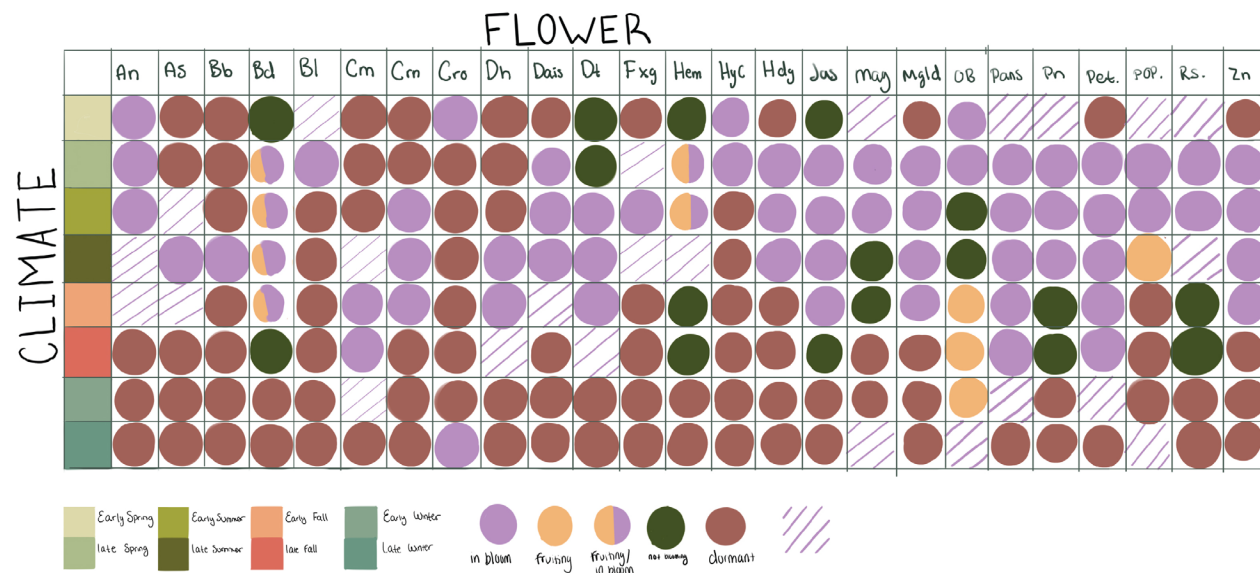

Diagram analyzing climatic conditions and their effects on flowers

# CHRYSANTHEMUM

CONDOLENCES  
COMFORT IN A TIME OF GRIEF

NATIVE TO: CHINA

↳ luck, health, love, cheerfulness, longevity  
rebirth,

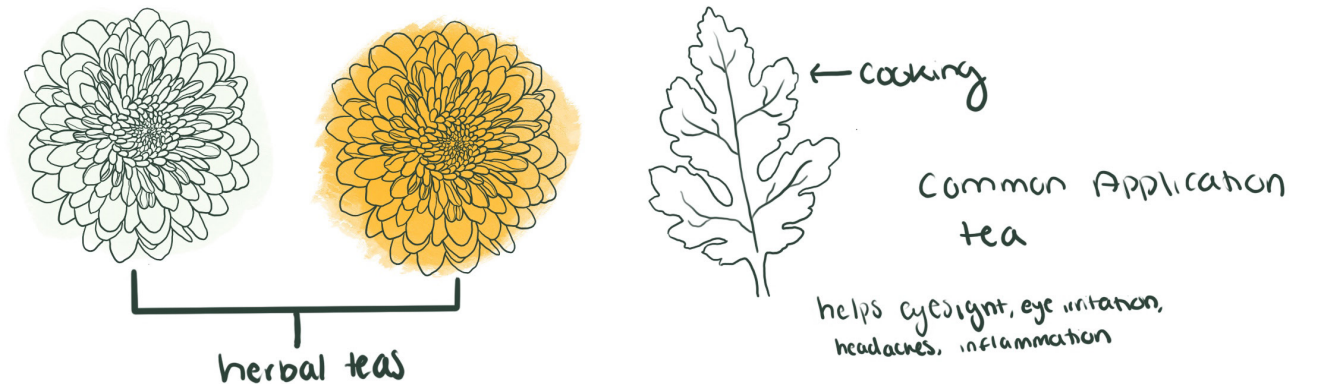
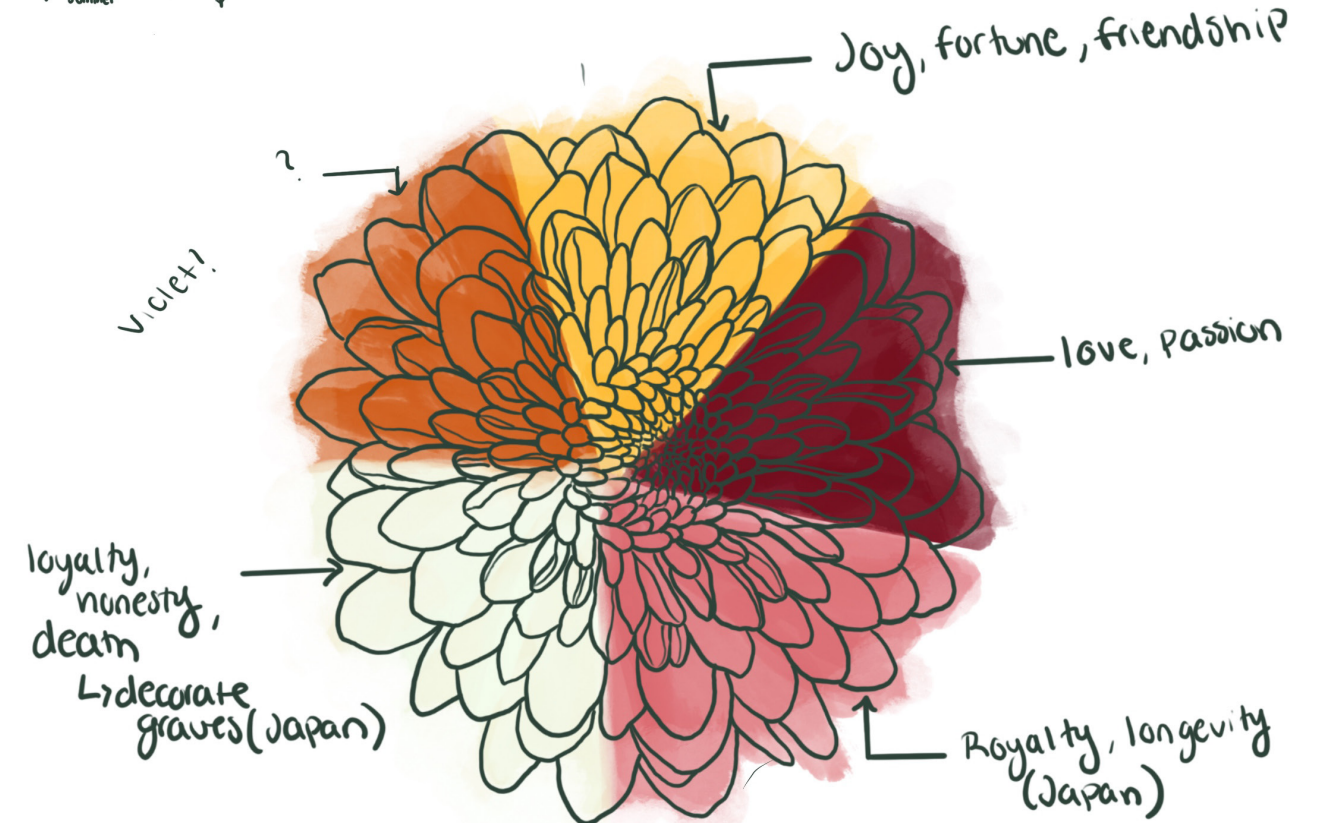

Diagram of a chrysanthemum, its medicinal properties, ideal growing conditions, and meanings



# Franklin Delano Roosevelt (FDR) Park

“I think FDR was forgotten about. And what’s happened is people themselves have had to make up for the lack of care from the city... It’s a really multicultural place. But it’s also a place that a lot of people don’t know...there’s a need to be more user friendly. It needs more bilingual support.”

- Carolina Torres Toledo, Volunteer Park Ambassador

---

“In the Language of Flowers” is set within Franklin Delano Roosevelt (FDR) Park in South Philadelphia. Once a bustling hub for outdoor activities, the park has faced a few decades of neglect due to a lack of funding from the city. The community has since been tasked with maintaining the park and creating a functional space for a variety of people from diverse and multicultural backgrounds. Both community effort and renewed interest in Philadelphia’s green spaces has slated FDR Park for a major renovation. It is also the 2021 location for the world-renowned annual Philadelphia Flower Show.

The exhibition builds on the tradition of the Flower Show and investigates revitalizing the park through an expanded partnership. “In the Language of Flowers” utilizes the defunct golf course area of the park as the backdrop for a lesson in Floriography.

---

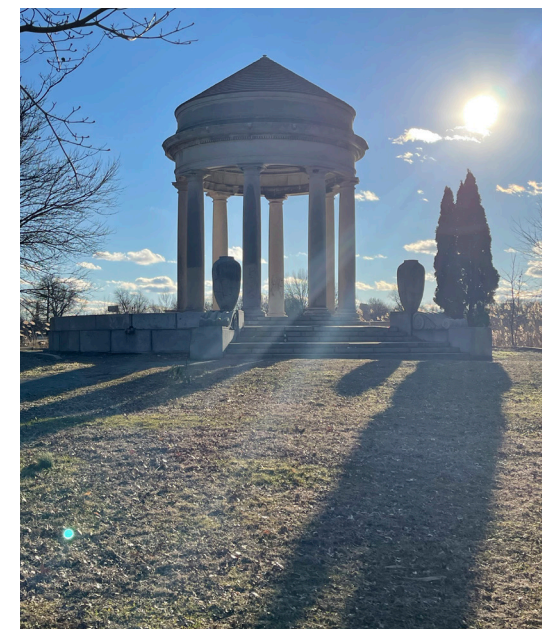
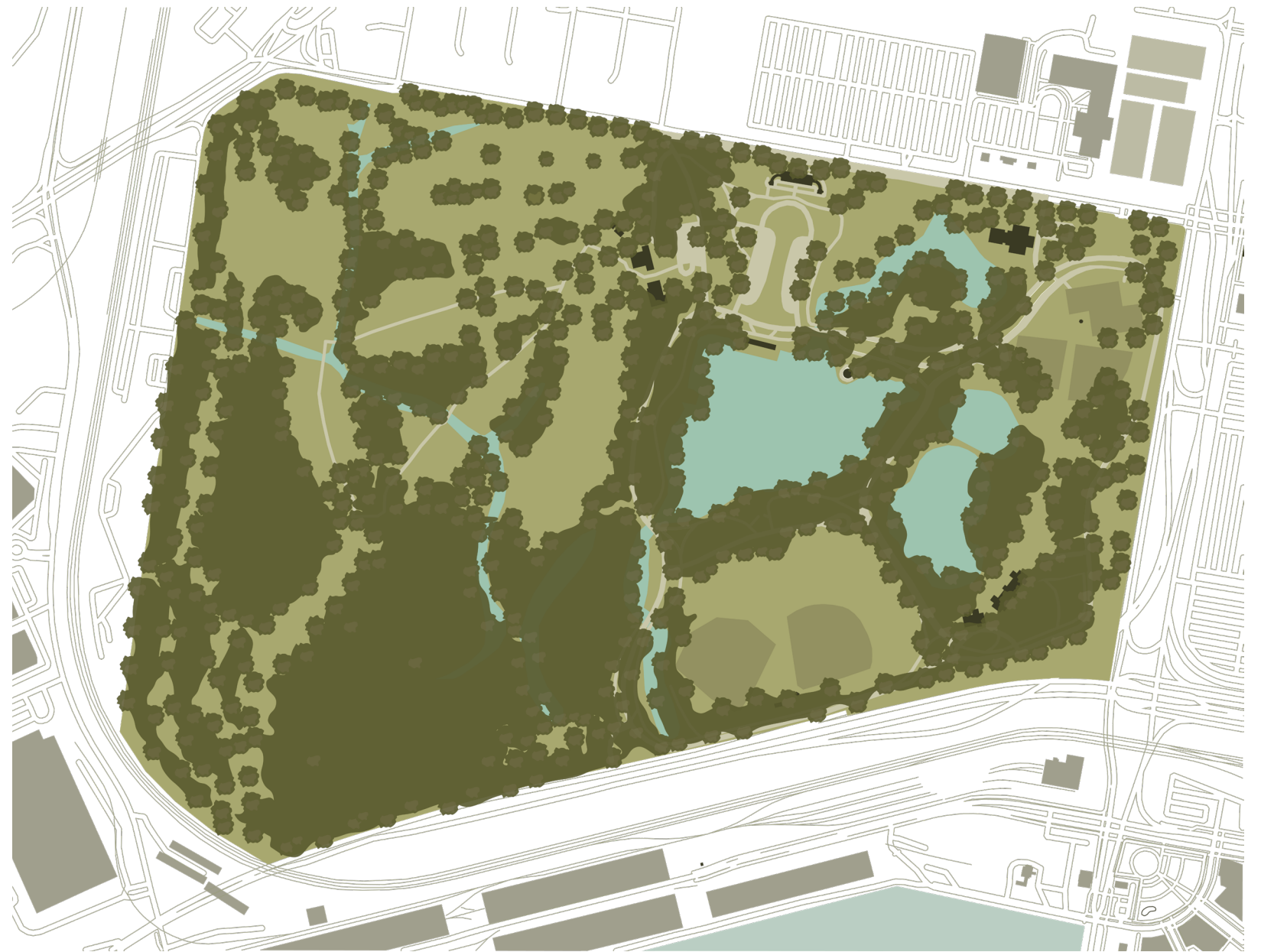



# The Flower Show





# Natural Conditions





# Human Interaction





# Ikebana

Ikebana is the Japanese art of floral arranging. It dates back to the Heian period (794 AD - 1185) and the arrangements would be used to decorate the tokonoma (space for displaying art and decorative pieces) of a traditional Japanese home. Traditional Ikebana is an art form that practitioners spend years to master. However, modern Ikebana has inspired much of the floral design world.

The vertical and sculptural nature of Ikebana served as an inspiration for some of the elements of "In the Language of Flowers." I specifically analyzed it for some of its structural elements to understand how it was possible to achieve such



Traditional tool used in classical Ikebana arrangements for structural support



Modern Kenzan tool used as structural support in many contemporary Ikebana arrangements



Ikebana arrangement by Thai Mai Van

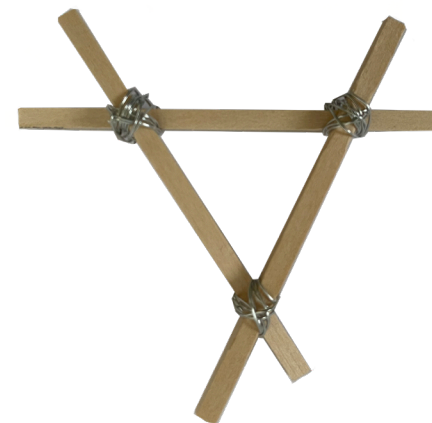

Exploration based on the traditional tool as a method for containing and holding flowers



Exploration based on the modern kenzan tool as a method for holding flowers. Custom built vase with a pin on the interior.





# Module One

## Interpersonal Communication

This module focuses on creating messages that can either give to someone else, or keep for themselves. Similar to the practice we already engage in of gifting floral bouquets to one another, visitors can utilize the teachings of the exhibition to create messages that they away can take from it.

This module utilizes the explorations of the traditional tool to create a structure that can hold the flowers. It is also adjustable to accomodate arrangements of varying sizes.

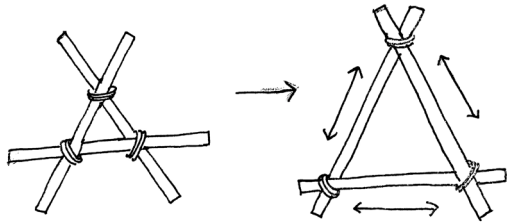
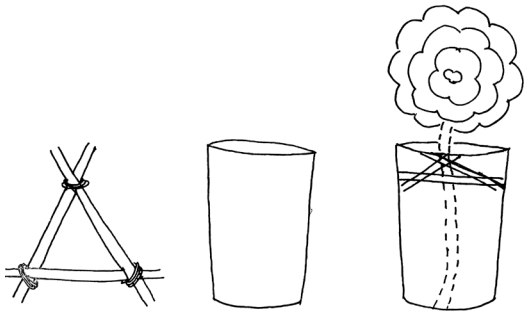

Early explorations

The tool can be adjusted to accomate a variety of arrangement sizes



# Creating a Message of Love

## Step 1: Determine Colors Associated with love

Red and Pink are most commonly associated with love

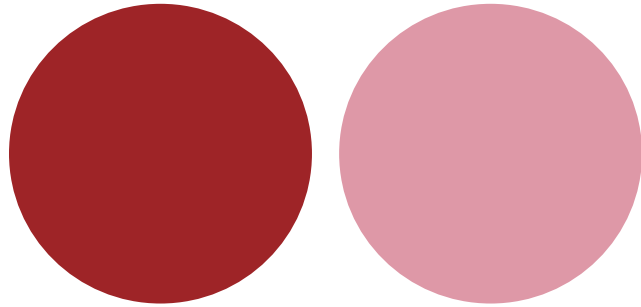

Another option could include yellow which is related to joy and comfort, both of which love can bring

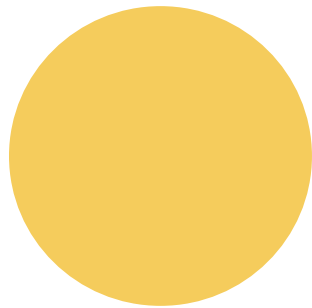

## Step 4: Determine What Foliage Could Further Emphasize The Intended Message

Some options would be:



Ivy: Fidelity/Attachment



Eucalyptus: Protection

## Step 2: Determine Flowers that Have Meanings Related to Love

There are hundreds which would all be presented in the dictionary but a few options would be:



Roses: Love



Myrtle : Love



Tulip: Deep Love



Orange Blossom:  
Eternal Love



Dahlia: Commitment



Honeysuckle: Devotion



Camellia: Longing

## Step 4: Combine the Elements of Your Message

If there is a certain point you want to emphasize, you can add more of that flower to your message





# Module Two

## Messages to the Community

Module two places emphasis on creating floral messages to the community as a whole. Sculptures, which serve as beacons to different areas of the exhibition, can be interfaced on with the messages that visitors create.

This module utilizes the explorations of the traditional tool but also investigates three different styles of Ikebana—Rikka, Seika, and Moribana—as an inspiration for shape of the sculptures.



Early explorations





# Rikka

Rikka is the oldest form of Ikebana. It focuses on the natural landscapes and each element of a rikka arrangement encapsulates an element of the natural landscape within the vessel. Rikka shofutai has a set traditional form as seen in the diagram below. On the left are explorations I made attempting to turn this diagram into a sculptural structure using the triangular shape of the traditional ikebana tool.



Rikka Arrangement

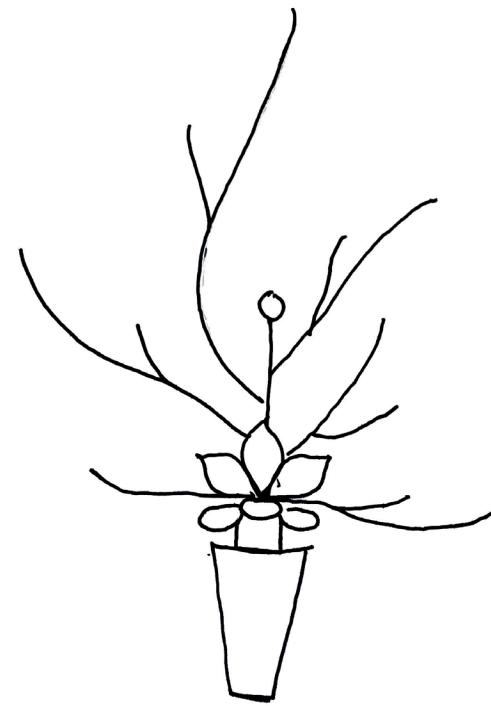

Rikka Diagram

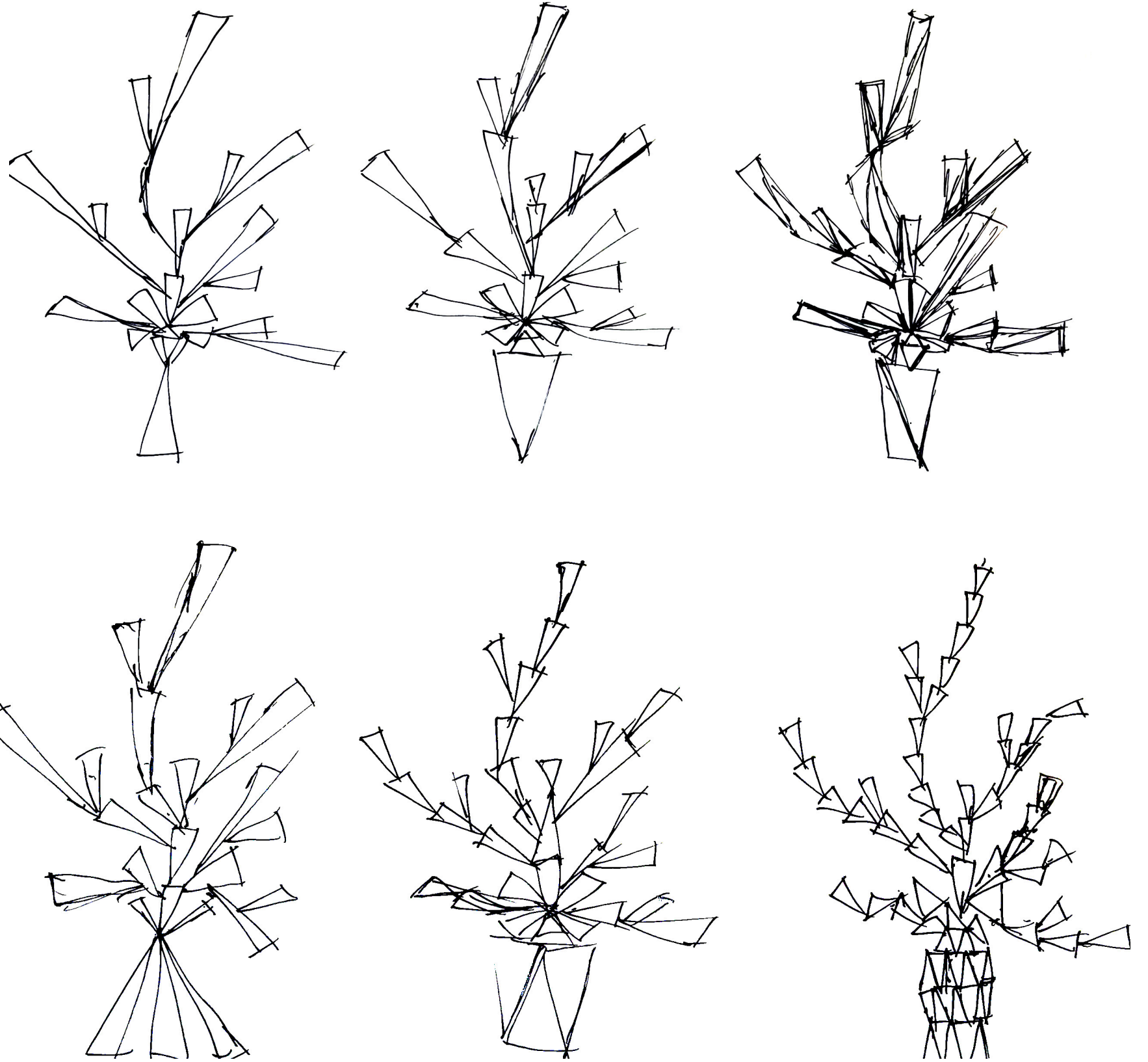

Rikka sculpture explorations



# Seika

Seika, also known as Shoka, was popularized in the late Edo period (1603-1868). It expresses the inner beauty of a plant at each stage of growth. Seika investigates the beauty of each of these stages and honors the efforts of a plant's will to live. Like Rikka shofutai, seika shofutai has a set traditional form as seen in the diagram below. Similarly, on the left are attempts at turning this diagram into a sculptural structure using the triangular shape of the traditional ikebana tool.



Seika Arrangement



Seika Diagram

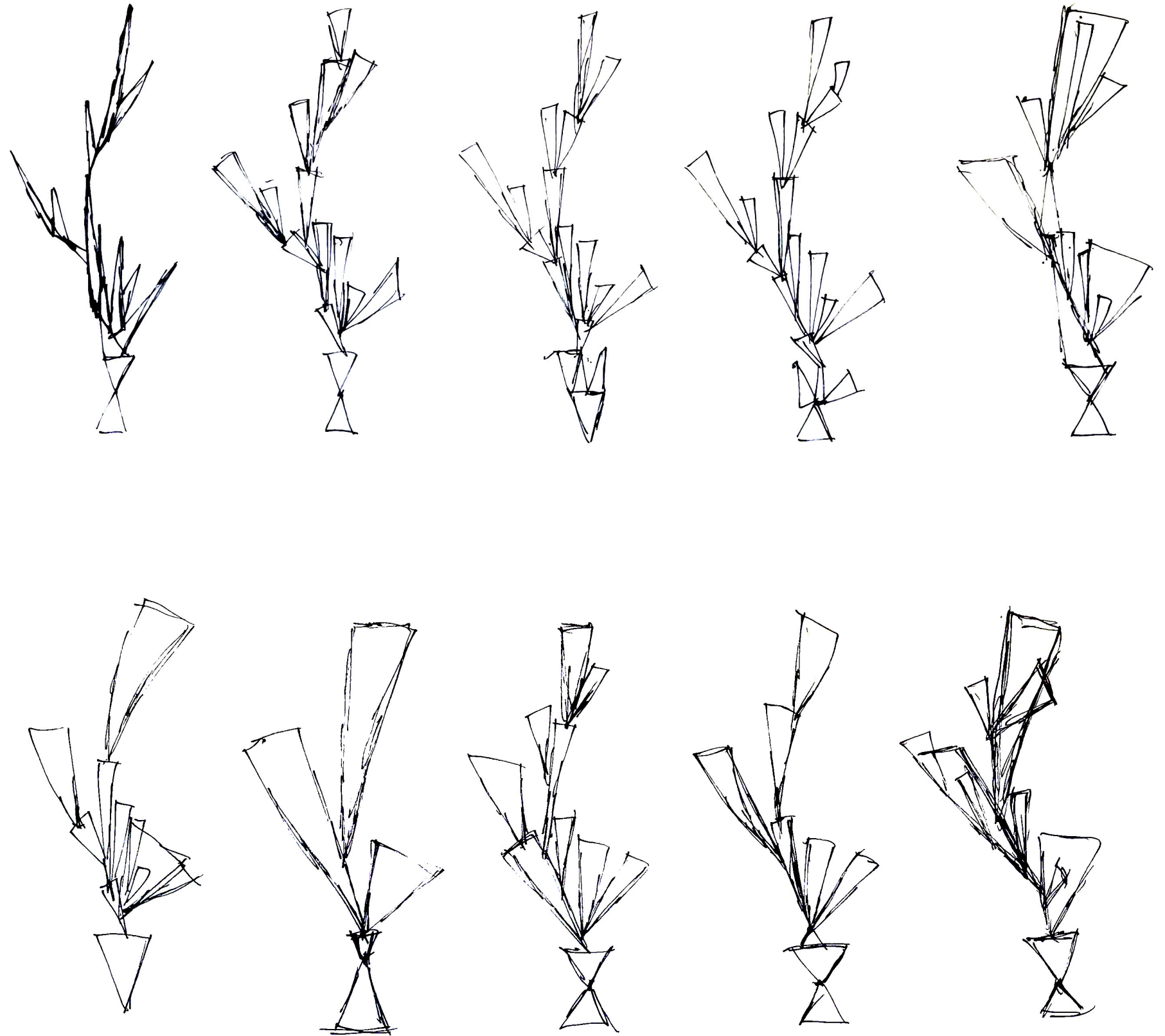

Seika Sculpture Explorations



# Moribana

Moribana translates into “piled up flowers.” It is a freeform version of Ikebana that does not have to adhere to a specific structure and can use items such as western flowers to create the arrangements. Moribana arrangements are often set in shallow vessels and allow for a wide arrange of expression. Some moribana arrangements can follow a basic structure as seen in the diagram below. I also used this diagram to explore methods of creating a sculpture inspired by the structure of moribana arrangements.



Moribana Arrangement

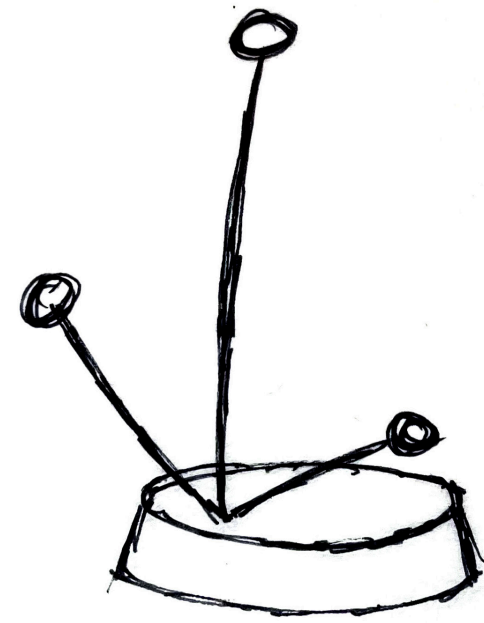

Moribana Diagram

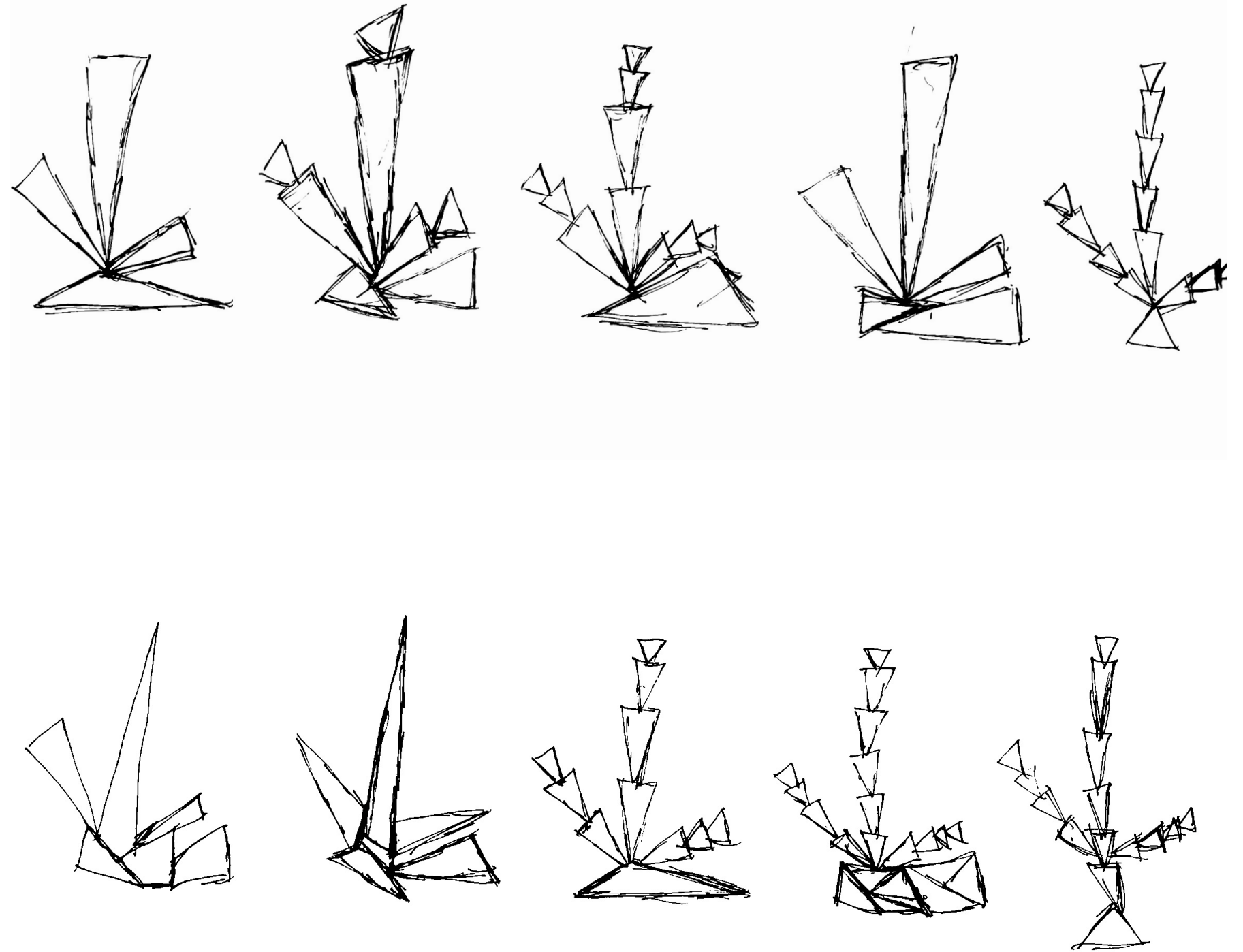

Moribana Sculpture Explorations



# Details

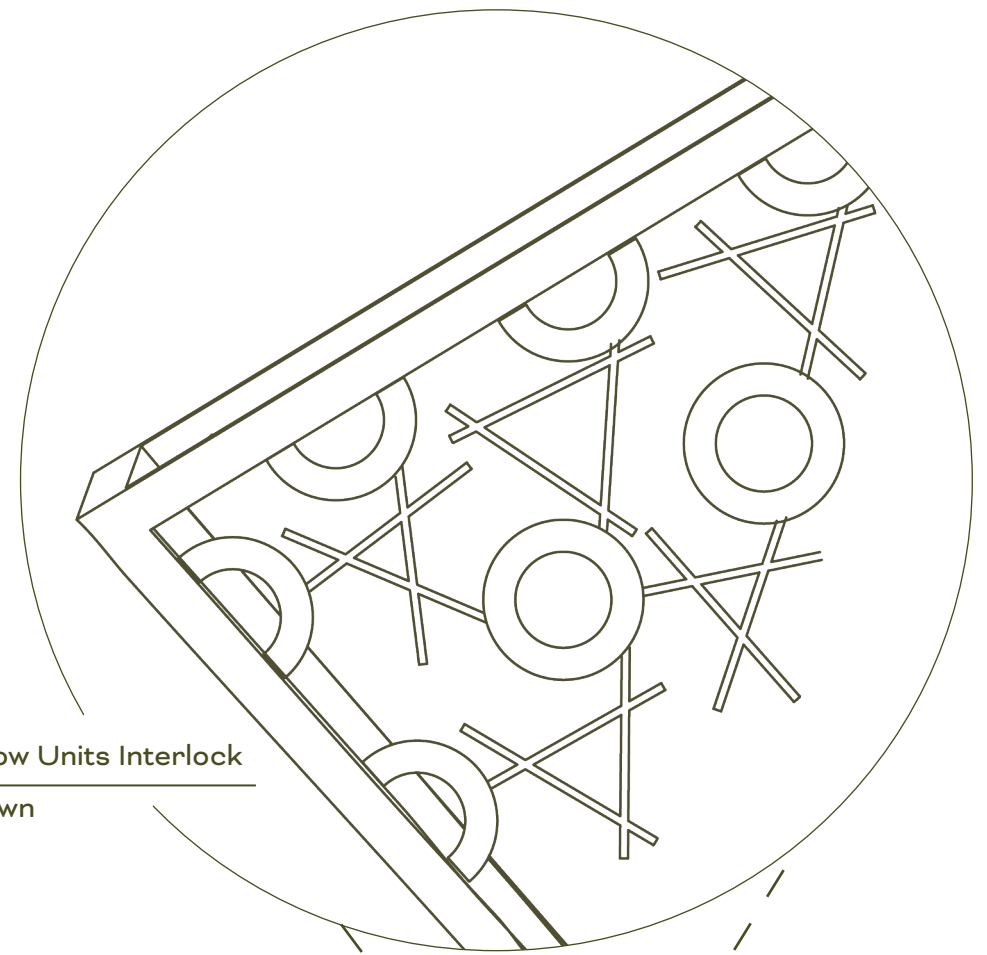
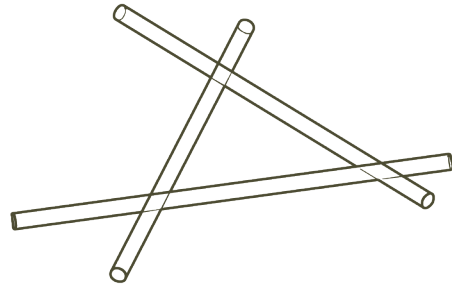
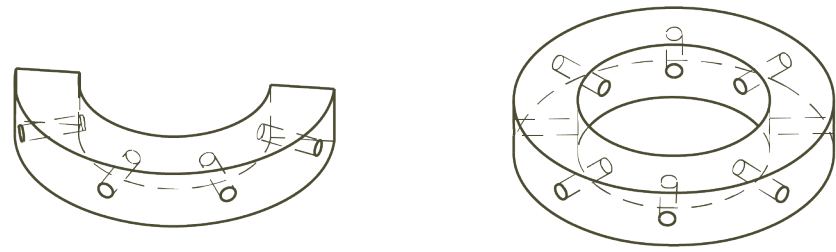

1 Units Used to Interface Floral Messages on Sculptures  
Scale: 2" - 1'

2 Example of How Units Interlock  
Scale: As Shown

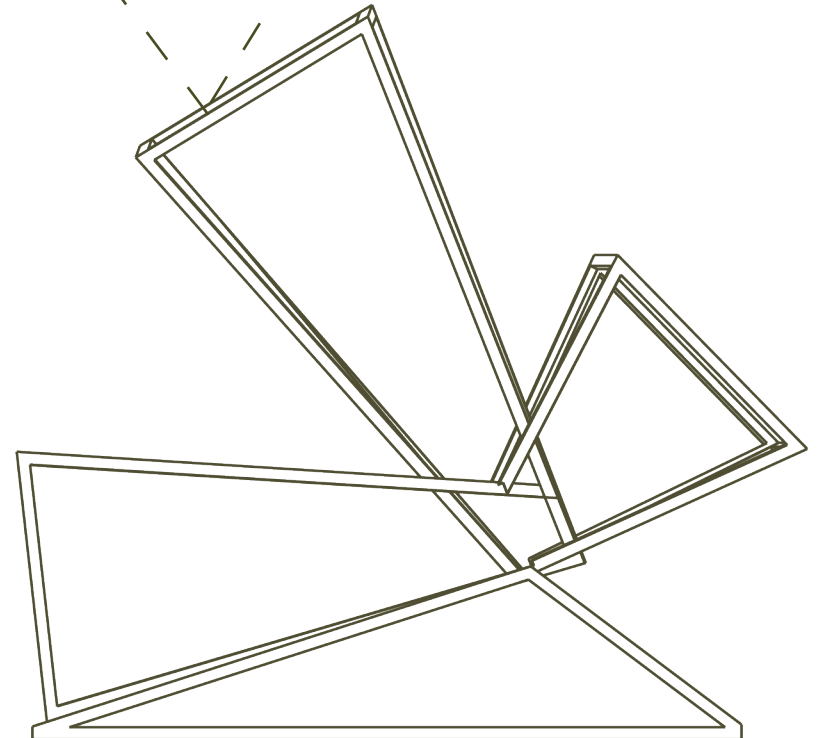
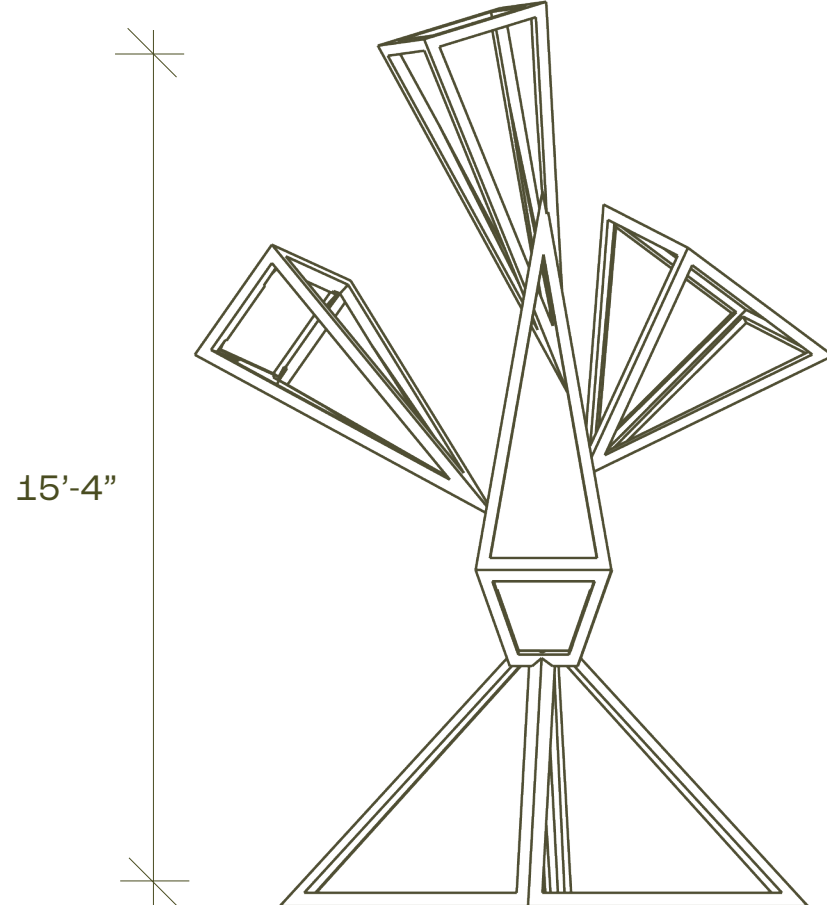
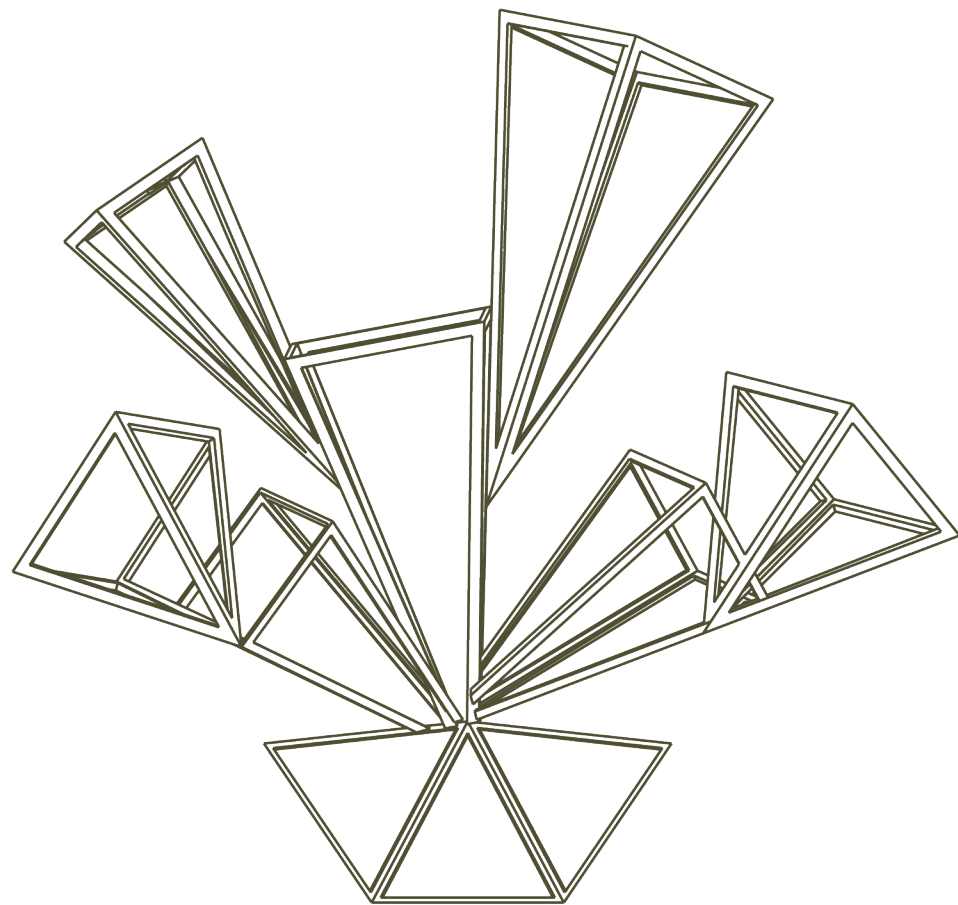

3 Front Elevations of Rikka, Seika and Moribana Sculptures  
Scale: 1/4" - 1'



# Creating a Message of Friendship

## Step 1: Determine Colors Associated with friendship

Yellow and Purple are most commonly associated with friendship



Another option could include pink which is related to love and affection

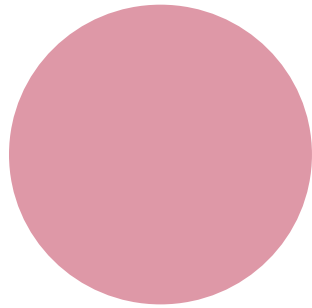

## Step 2: Determine Flowers that Have Meanings Related to Love

A few options would be:



Roses: Love



Zinnia: Everlasting Friendship



Pansy: Thinking of You



Jasmine: Cheerful



Sweet Pea: Gratitude



Apple Blossom: Preference

## Step 4: Determine What Foliage Could Further Emphasize The Intended Message

Some options would be:



Ivy: Fidelity/Attachment



Eucalyptus: Protection

## Step 4: Combine the Elements of Your Message



Image Credit: Jessica Roux



# Module Three

## Messages to Nature

Module three focuses on creating messages specifically to nature, and to the park. This module utilizes the explorations of the modern kenzan tool to create a pliable fabric that flowers can attach to. The fabric can be wrapped around objects in the park such as trees, benches, and picnic tables.

This module creates message boards that interact directly with the objects that visitors are responding to. The flowers are what connect humans, nature, and the park.

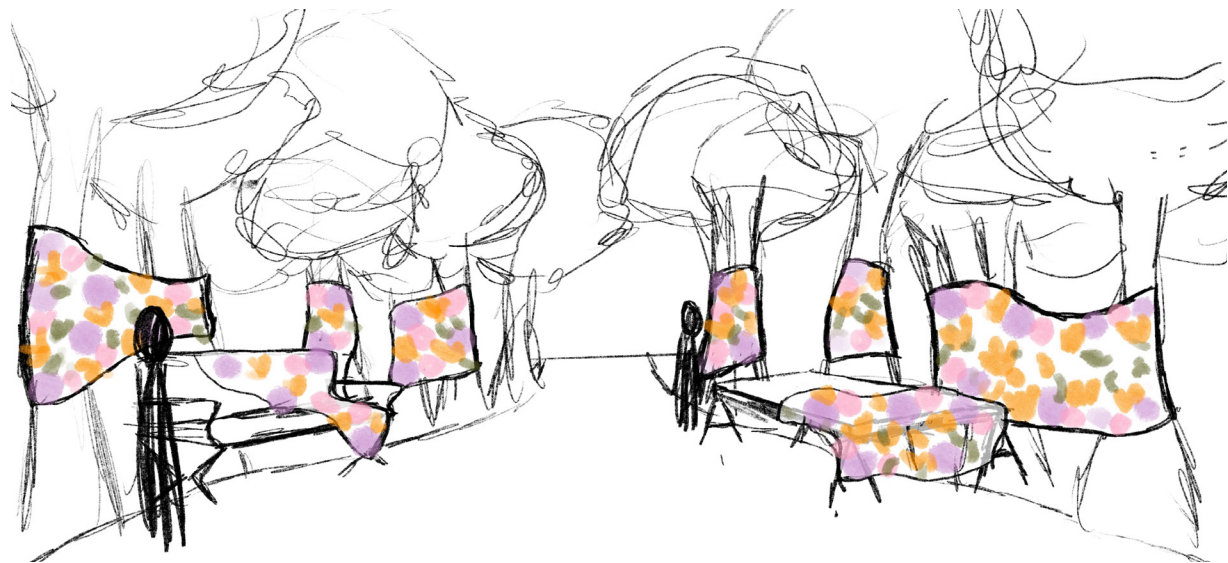

Early explorations

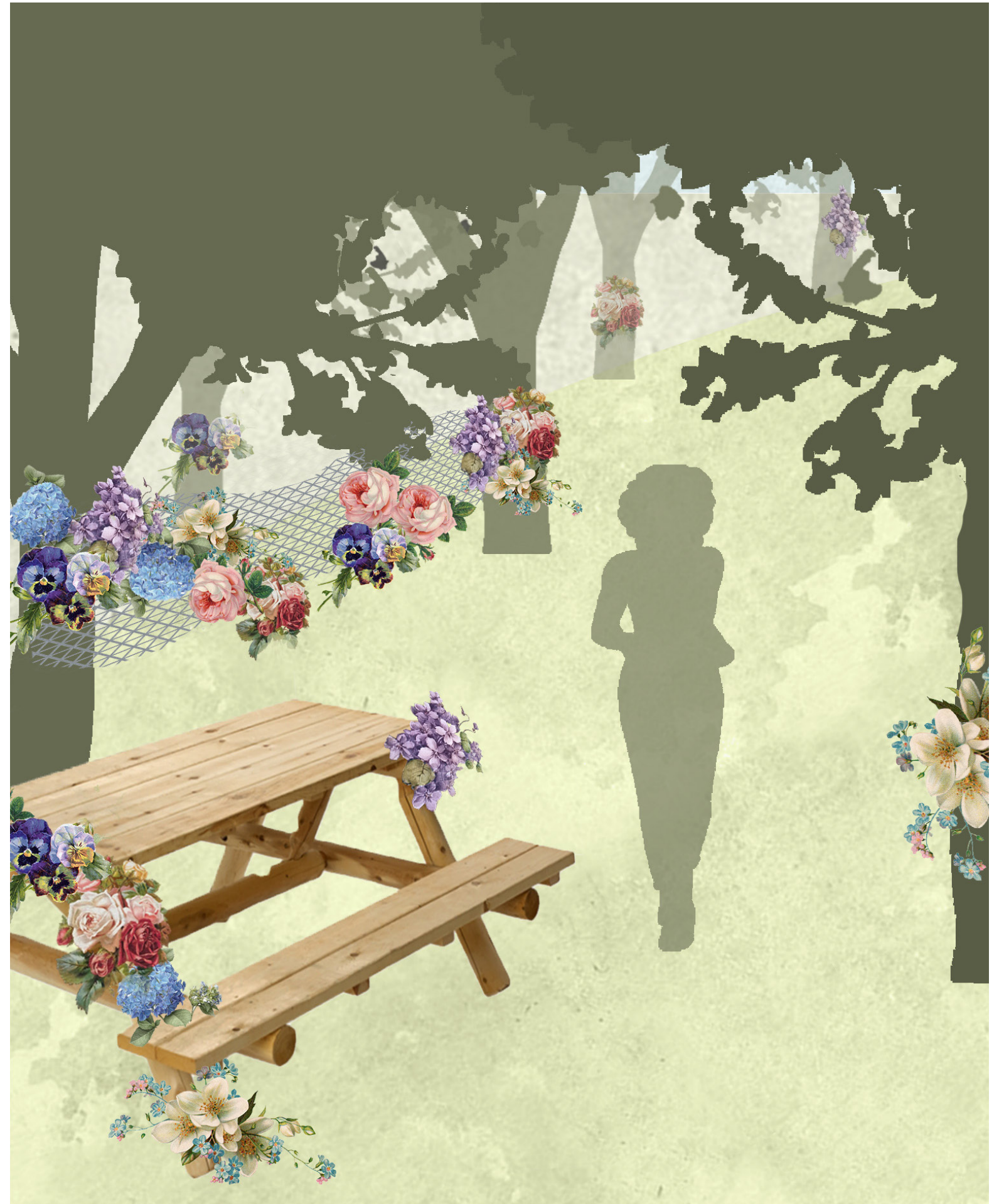



# Creating a Message of Hope

## Step 1: Determine Colors Associated with Hope

Orange, Green, and Blue are most commonly associated with optimism, hope and serenity.

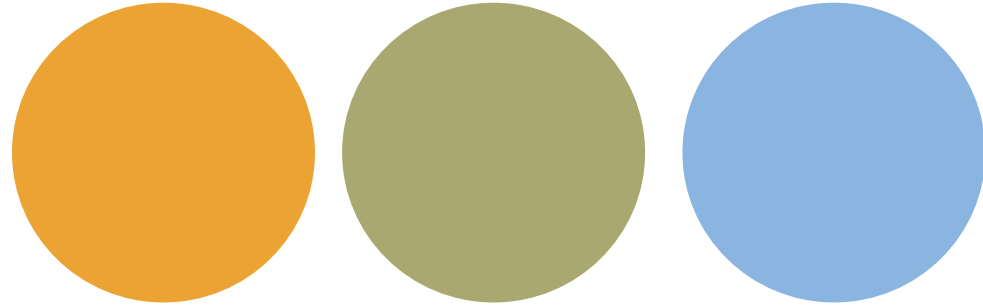

Another option could include white which is related to balance

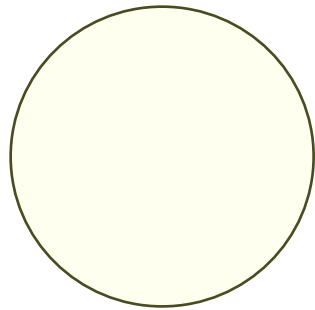

## Step 4: Determine What Foliage Could Further Emphasize The Intended Message

Some options would be:



Olive Branch: Peace



Cattail: Prosperity

## Step 2: Determine Flowers that Have Meanings Related to Hope

A few options would be:



Iris: Hope/Faith



Snowdrop: Hope



Hyacinth: Sincerity



Cornflower: Hope in Love



Daffodil: New Beginnings



Chrysanthemum: Hope

## Step 4: Combine the Elements of Your Message





# Module Four

## Storage

This module serves as a method for organizing the site and also helps to organize message creation. The storage units contain the cut flowers needed to create messages for the other modules within the exhibition so they are placed at intervals to appropriately supply each section. They are also used to separate flowers and foliage based on meaning help to guide the visitors through message making during their time in the exhibition.

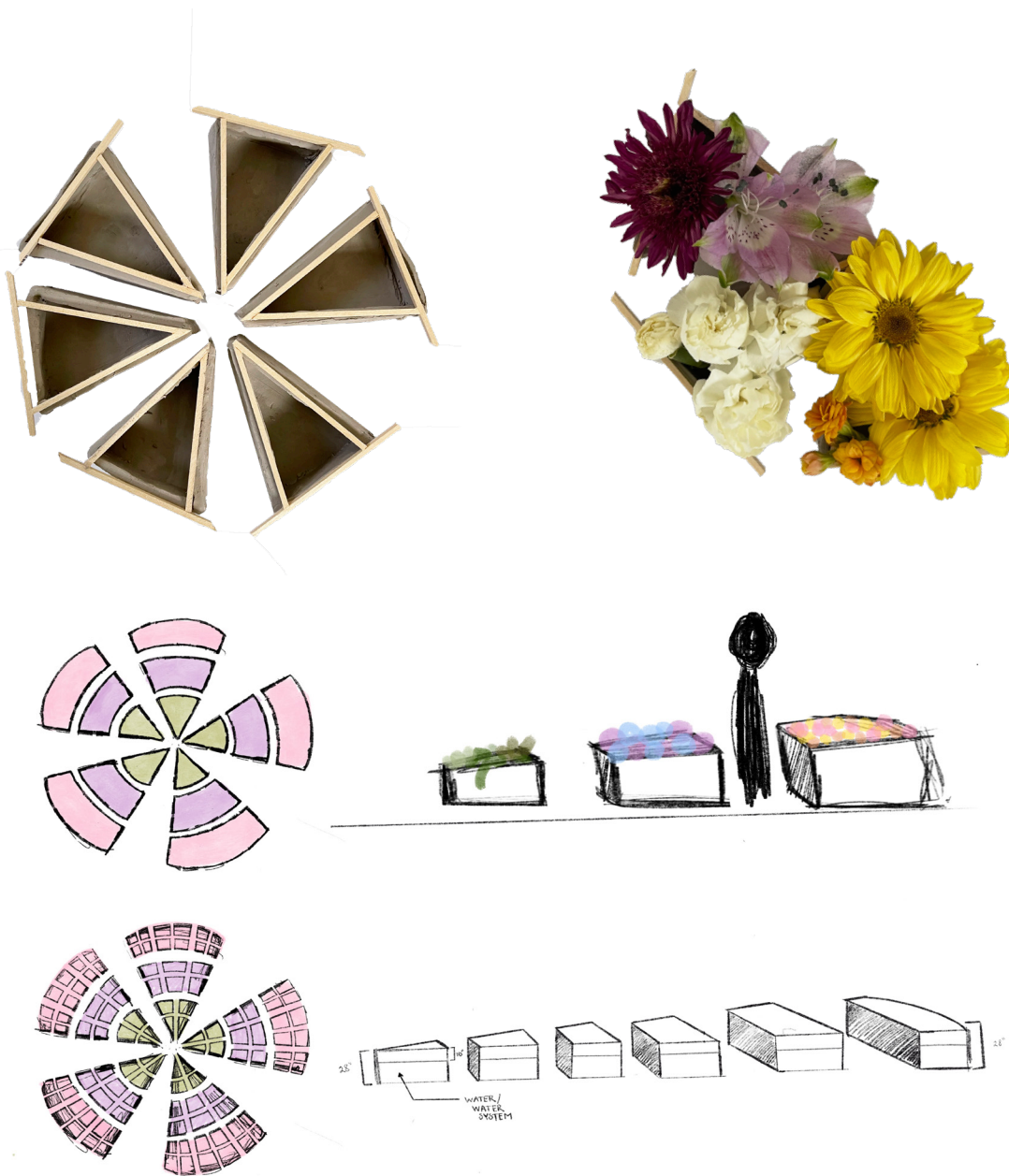

Early explorations





# Details

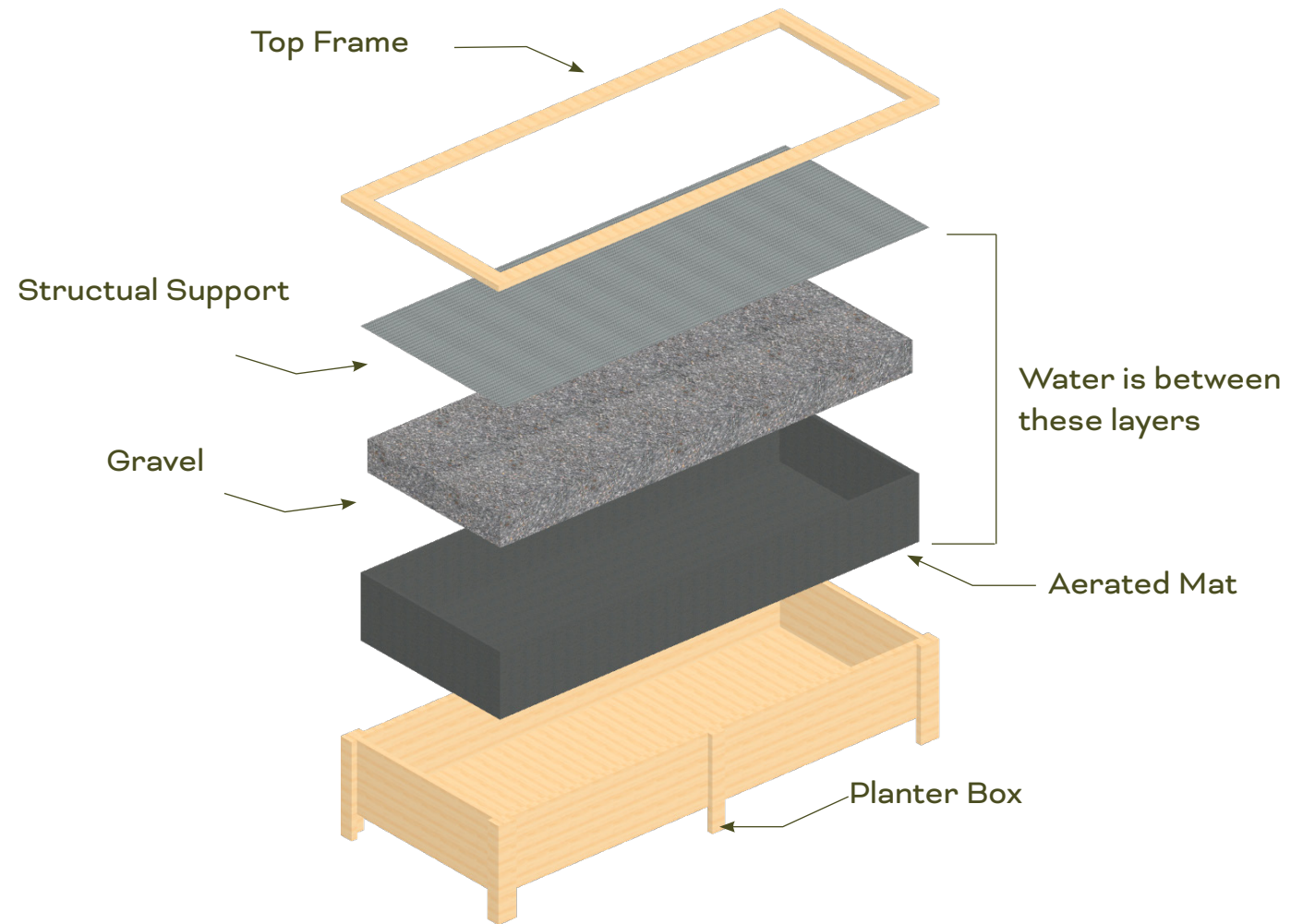

1 Exploded Axonometric of Storage Component  
As Shown

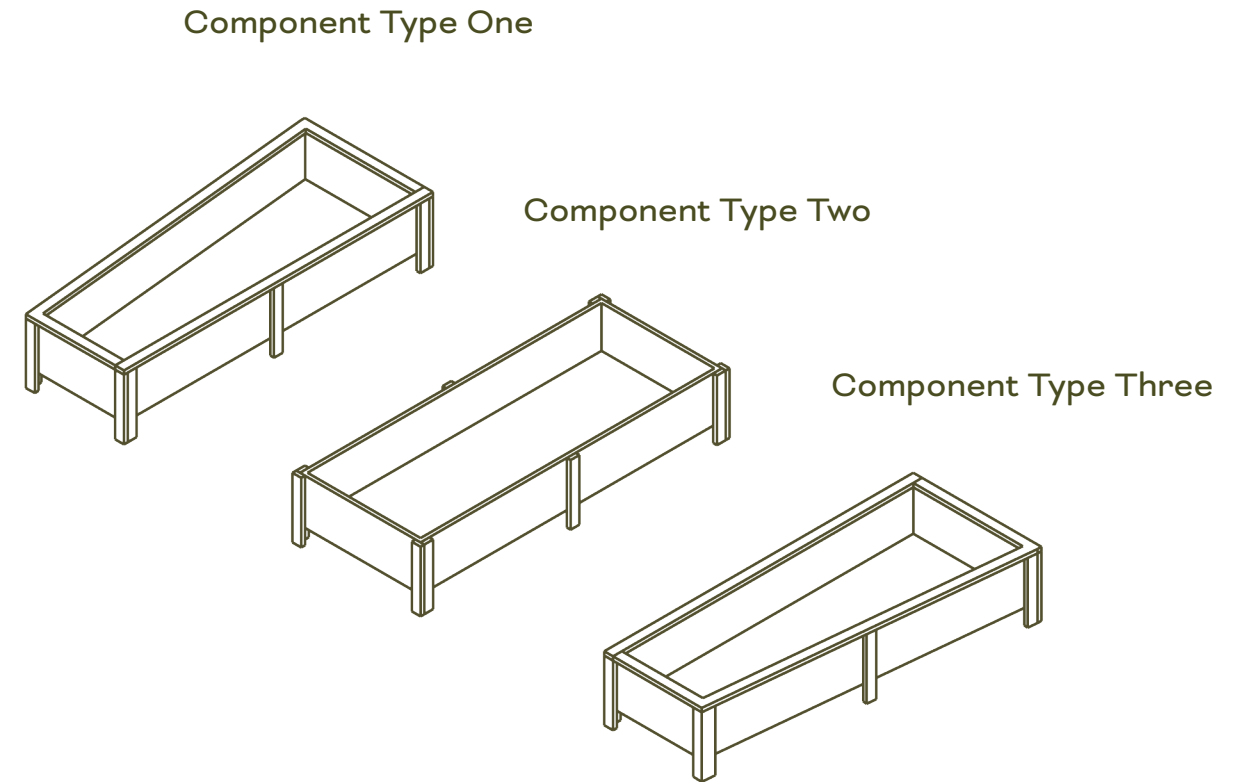

1 Isometric Drawings of Components 1, 2, and 3  
As Shown

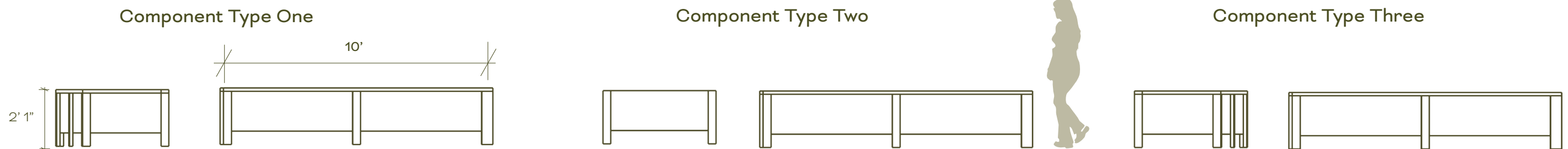

3 Front and Left Elevations of Component 1, 2, and 3  
Scale: 1/4" = 1'



# Using Module Three for Syntax

## Explanation

Each storage unit is organized to help visitors craft their intended message.

### Application 1

The largest section of the exhibition guides visitors through the different sections of the reimagined dictionary (well wishes/congratulations, gratitude, friendship, love, anger/displeasure, grief/sorrow sympathy, apology/forgiveness).

The storage units in this section will be separated by flowers that are directly associated with that message (i.e. roses meaning love) flowers that are more loosely associated with that message (i.e. dahlias meaning commitment). and then foliage that could be associated with that message (i.e. ivy meaning fidelity). All of the flowers provided in these sections will be in the colors that are also associated with that message.

### Application 2

In the more free-form and warm-up sections of the exhibition an assortment of all the flowers and foliage in the dictionary will be provided and group based on the dictionary section their meanings are associated with. Visitors can use to the provided dictionary, and their own intuition to form messages with these flowers.

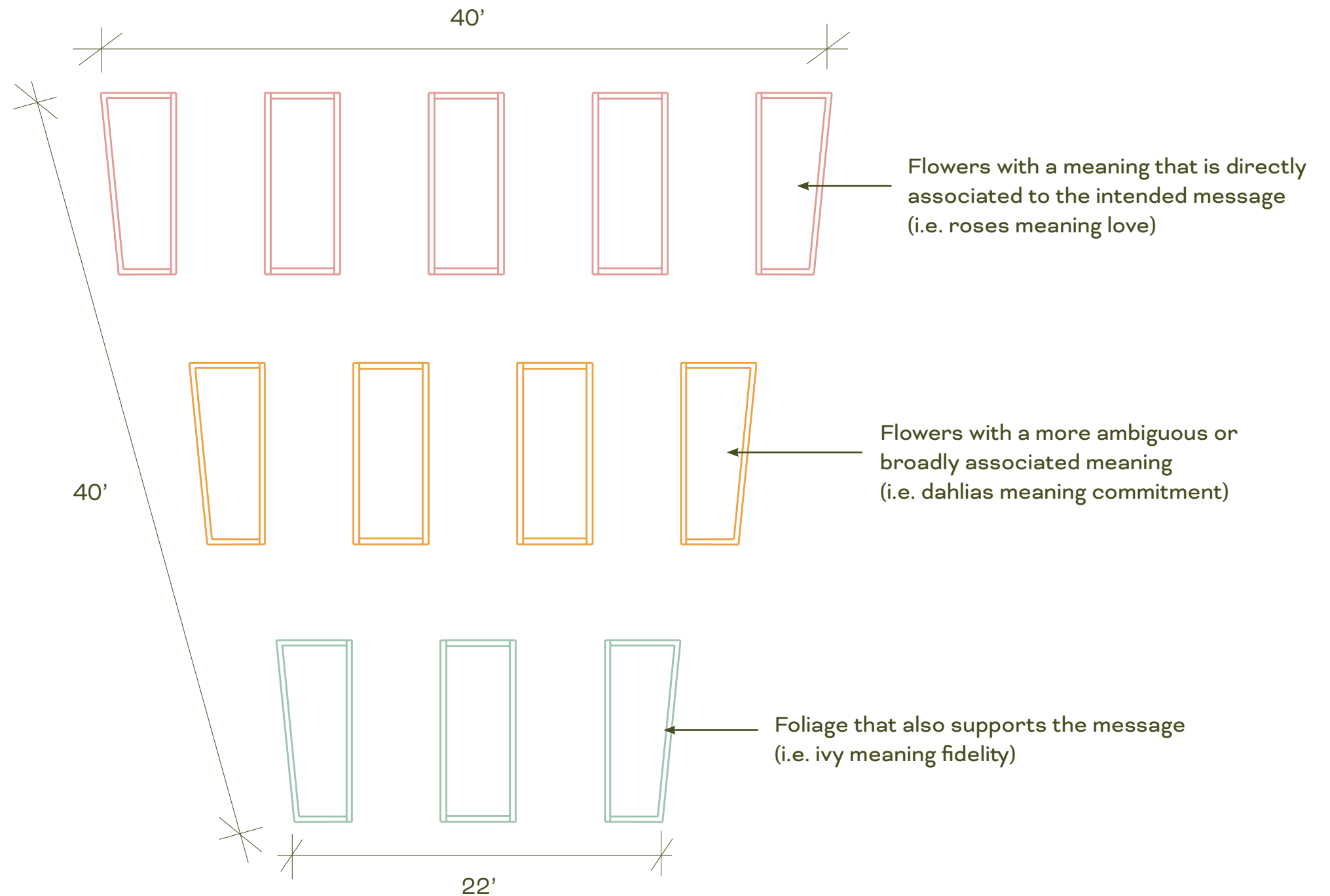



1 Overall Footprint of One Storage System  
1/8" = 1'

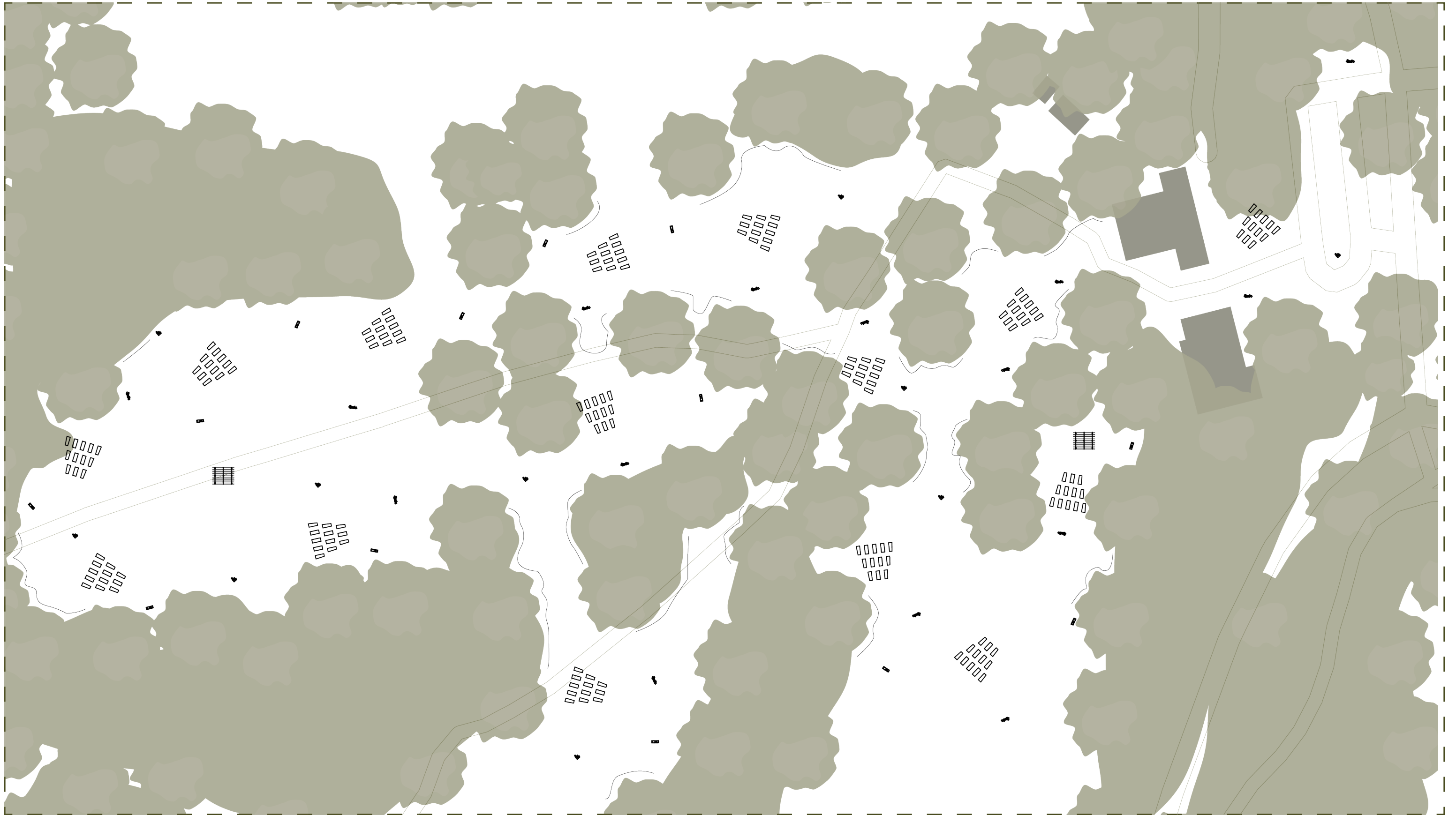

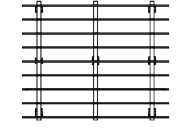

1 Exhibition Plan  
 Scale: 1/32" 

**KEY**

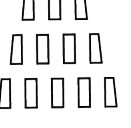
			
Module 1 Location	Module 2 Location	Module 3 Location	Module 4 Location



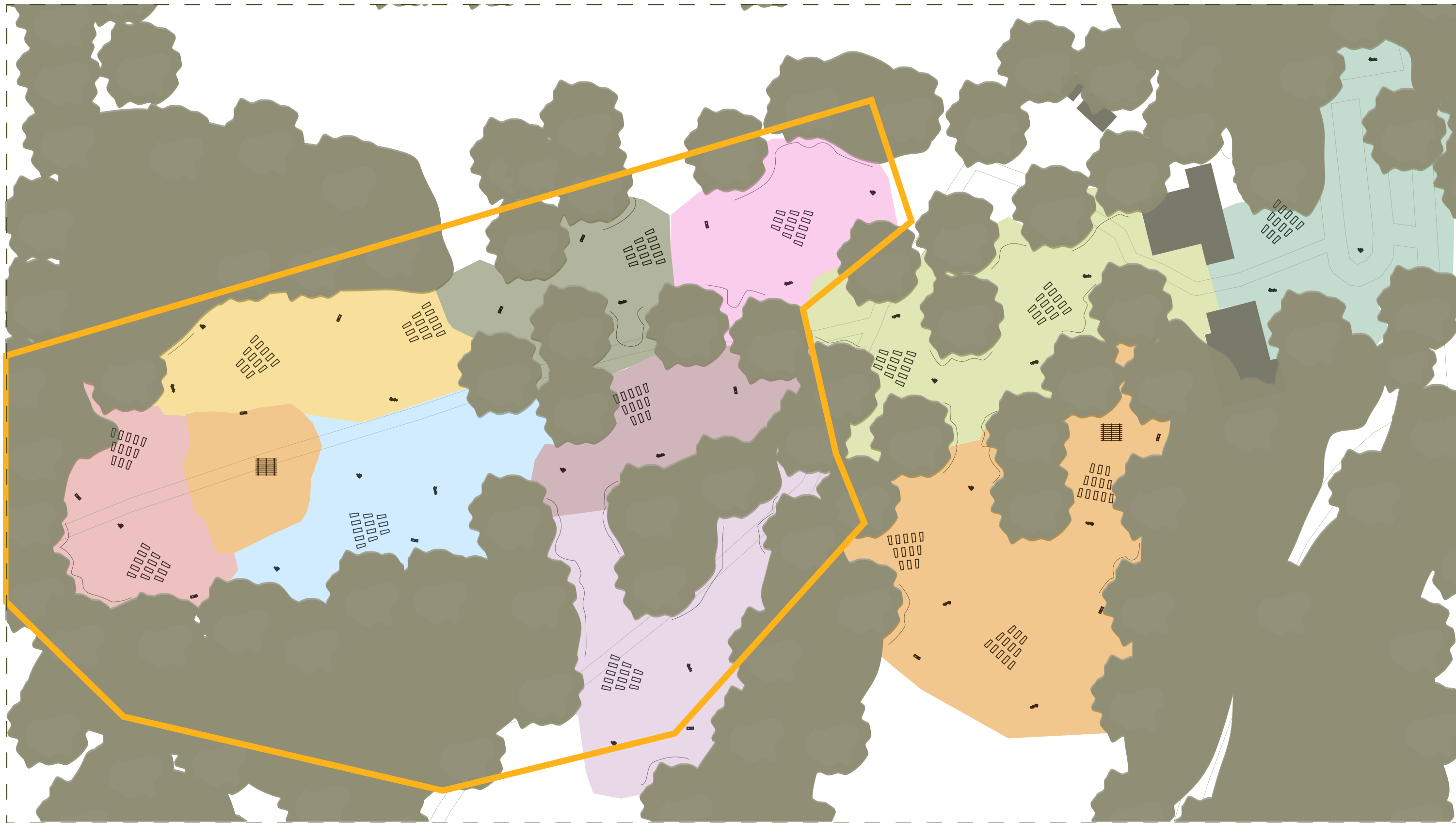

1 Exhibition Zones  
 Scale: 1/32"

**KEY**

 well wishes/ congratulations	 friendship	 anger/ displeasure	 apology/ forgiveness	 Intro Zone (has examples of pre-built messages )	 Warm-Up (visitors engage in floriography but don't have knowledge of dictionary yet)
 gratitude	 love	 grief/sorrow/ sympathy	 Zone of Specific Dictionary Sections	 Free-form message making Zones	



# Dual Purpose

Each module will serve a dual purpose. The first being for their use during the exhibition. After the exhibition is over, the module will be repurposed to serve various needs of the park.

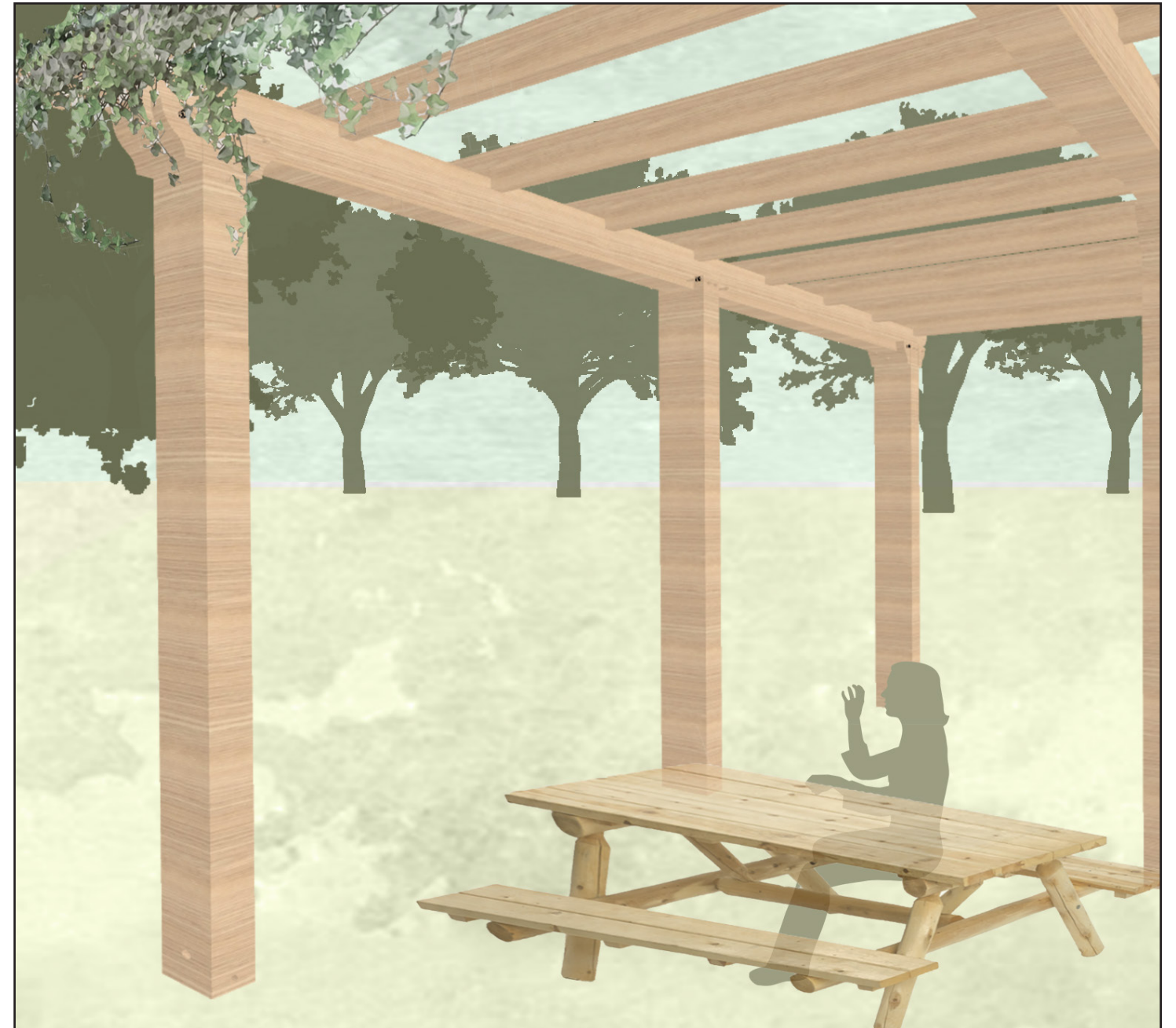
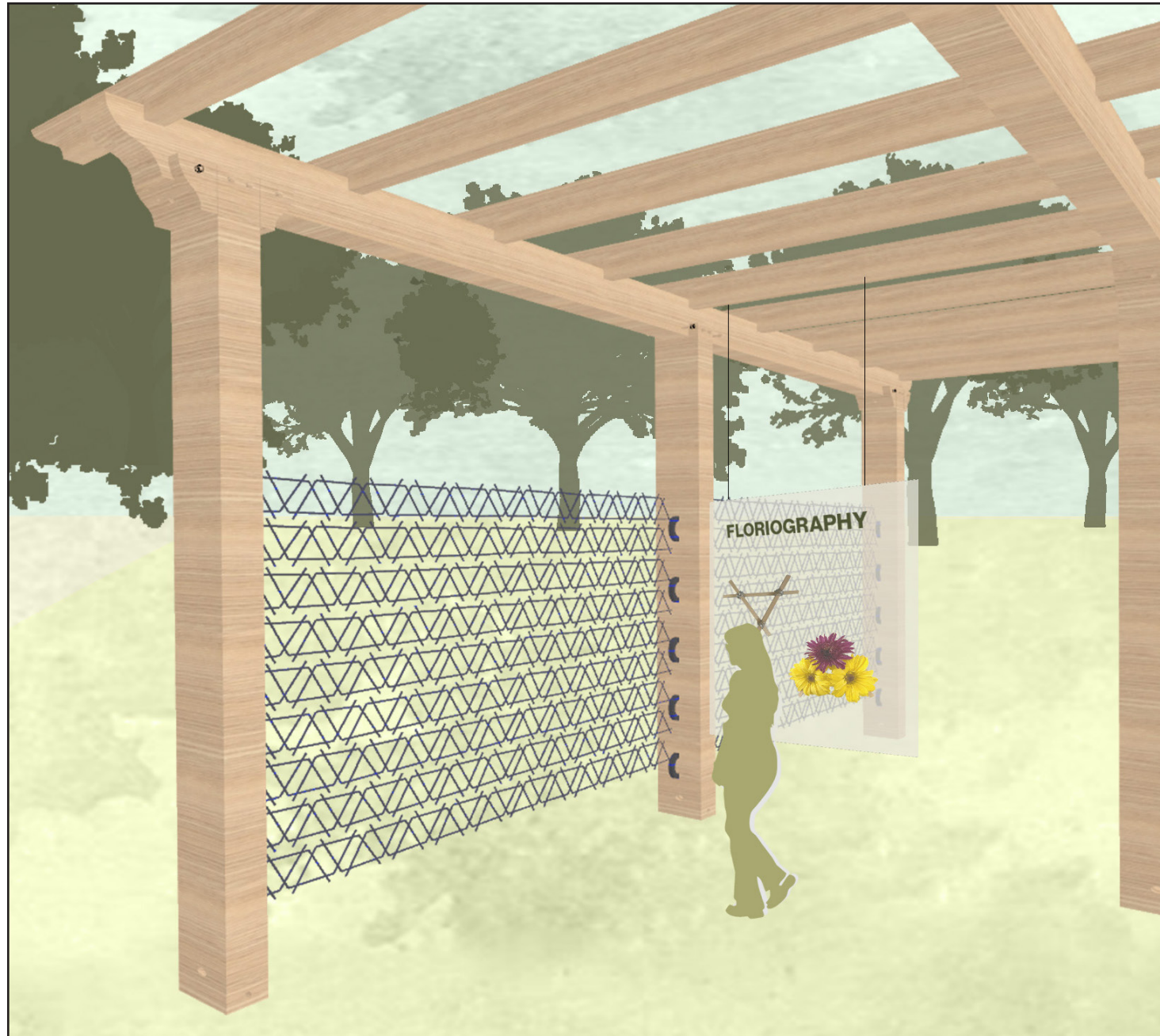

Module 1 will require pavillions to be constructed in order to house the supplies (tables, trimmers, flower holders, instructions, dictionaries, etc.) and give visitors a place to craft their messages. Afterwards, these pavillions can be used as regular park pavillions which do not currently exist in the golf course area of FDR park.





Module 2 will serve as a sculptural unit during the exhibition. Afterwards, these sculptures can be used to support native flora and in turn provide important habitats for fauna within the park.





The mesh of module 3 will support the kenzan structure during the exhibition and can be embedded into the ground to help prevent soil erosion after. FDR park faces issue with soil erosion due to frequent flooding in certain areas.





Module 4 is built using large raised planter beds as a base and modified to accommodate cut flowers and water. After the exhibition, they can be repurposed into portable community garden beds. These beds can exist within FDR park but can also be filtered to the surrounding area since there will be 180 individual units built for the exhibition.



# Credit

**Botanical Illustrations (on pages 9, 15, and 17) and Victorian Floriography background:**

1. Jessica Roux, "Floriography: An Illustrated Guide to the Language of Flowers"

**Ikebana Background Information and Imagery:**

1. Shozo Sato "Ikebana: The Art of Arranging Flowers"
2. Ikenobo School of Ikebana, Kyoto, Kyoto, Japan

**Color Theory**

1. Darroch Putnam and Michael Putnam "Flower Color Theory"

