

# Attention Allocation in Decision Making as Optimal Sequential Sampling

Fred Callaway  
Princeton University

The 2019 Sloan-Nomis Workshop on the Cognitive Foundations of Economic Behavior

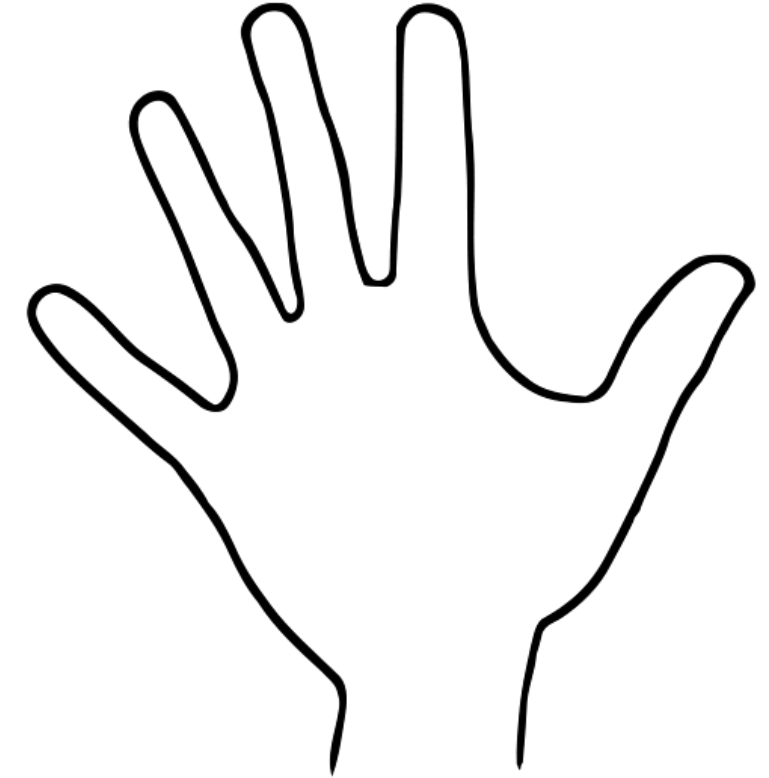

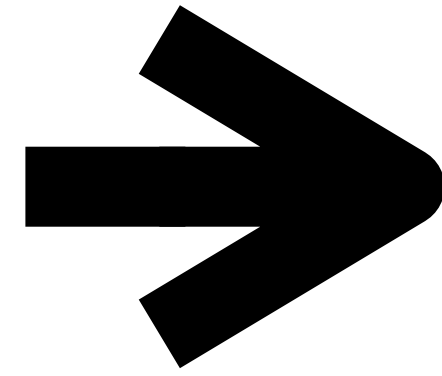
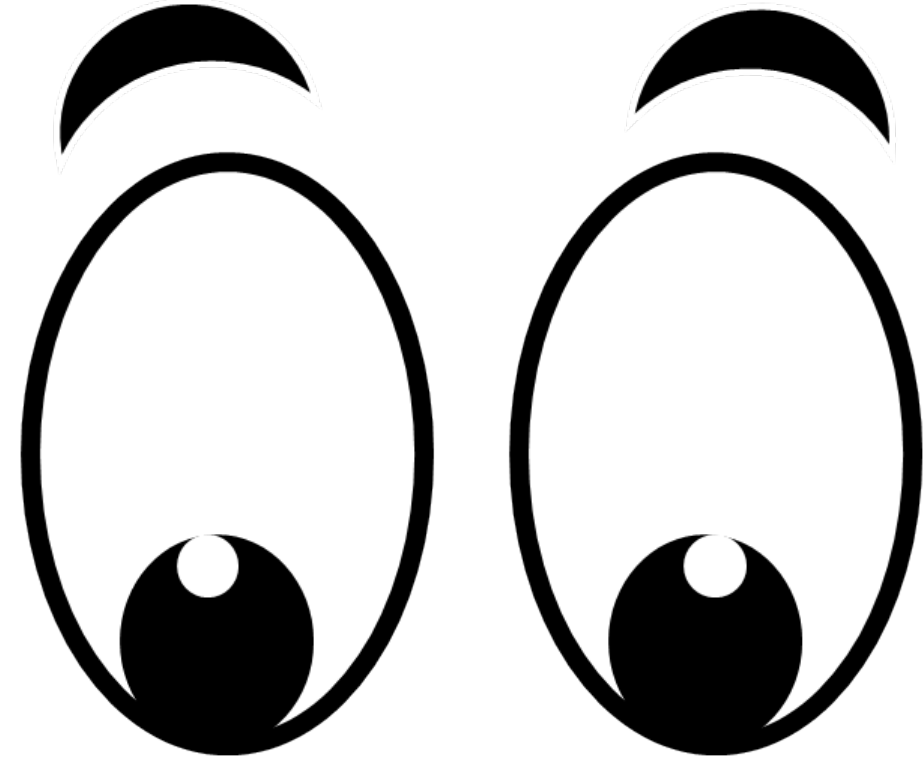

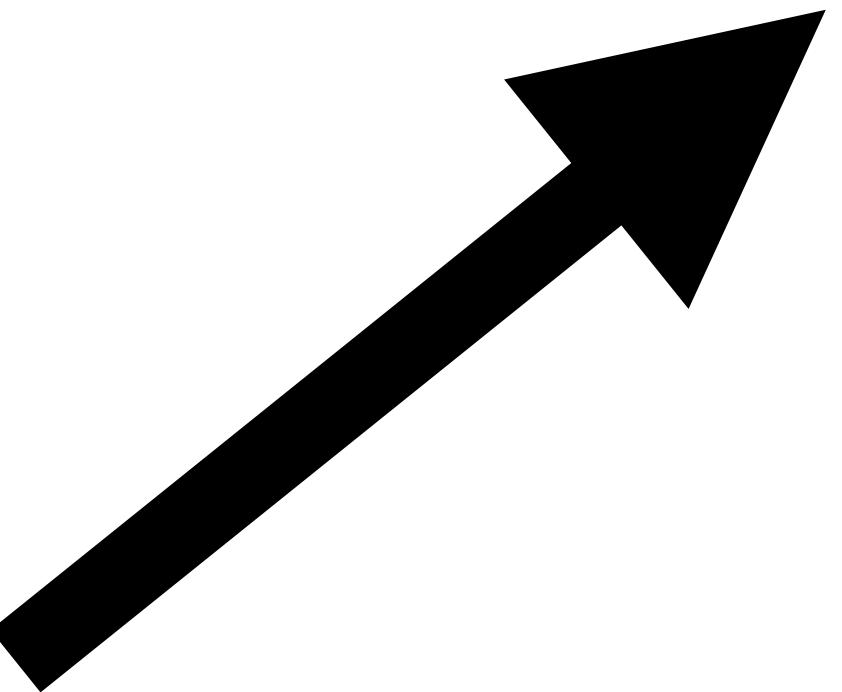
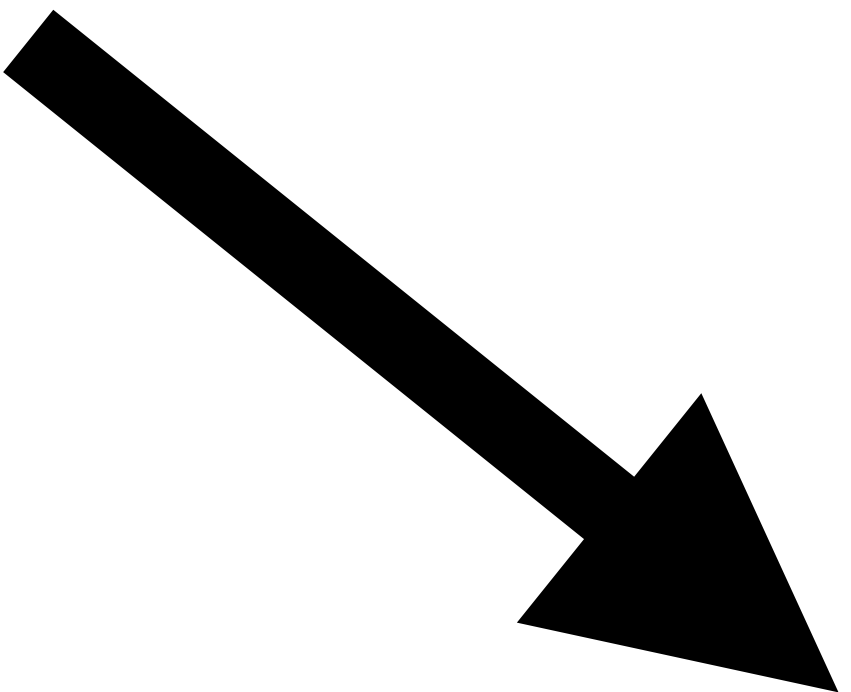
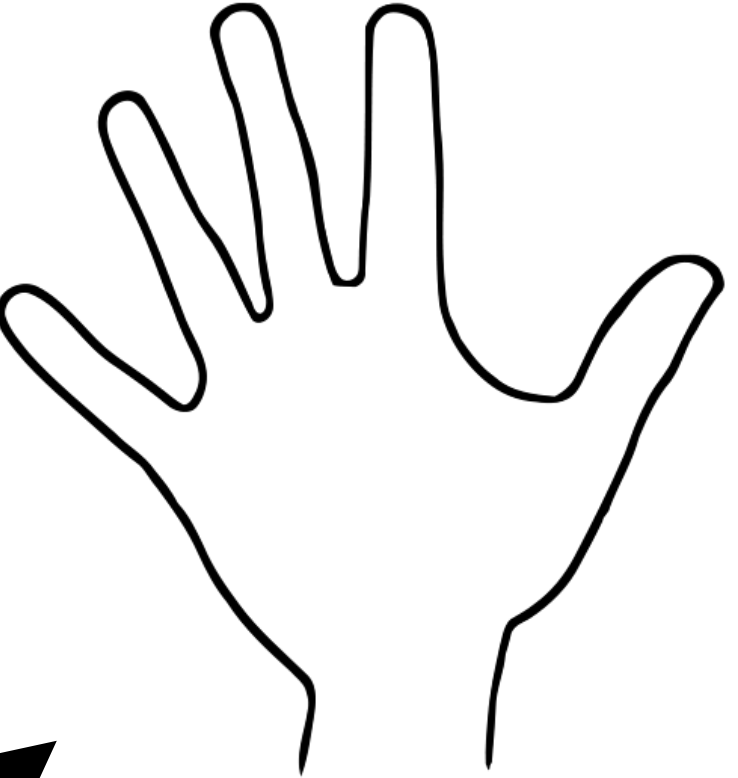
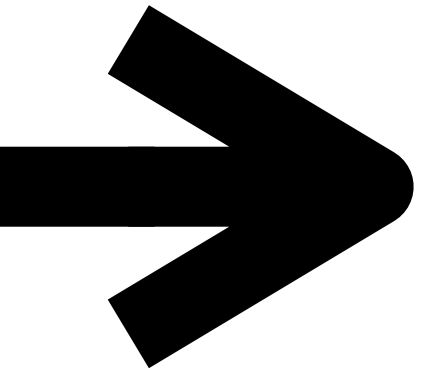
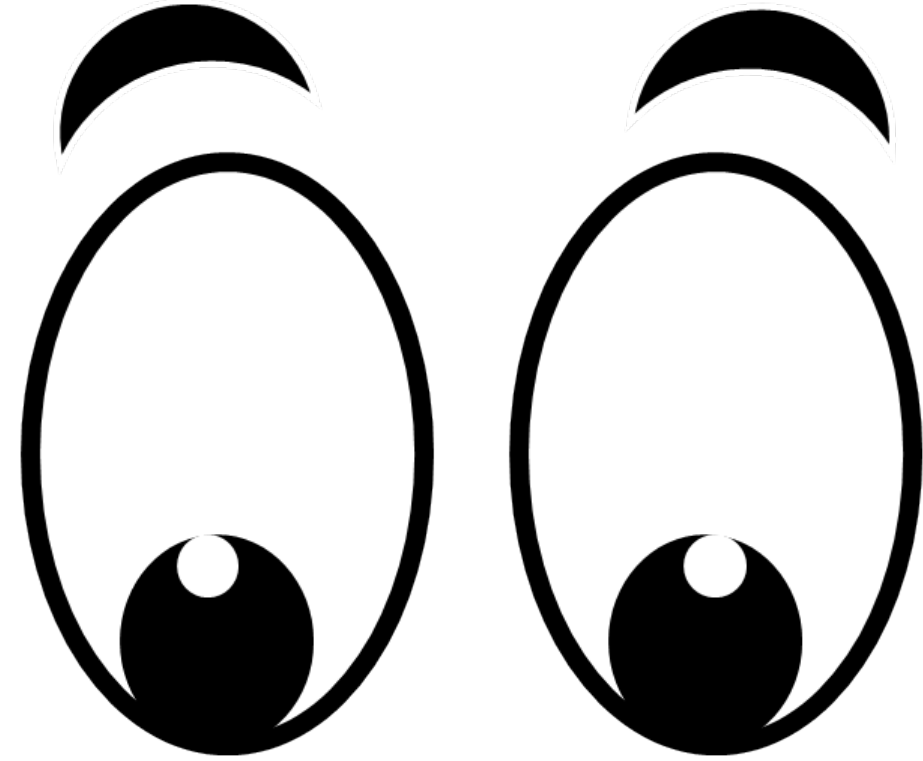

# Attentional drift diffusion model

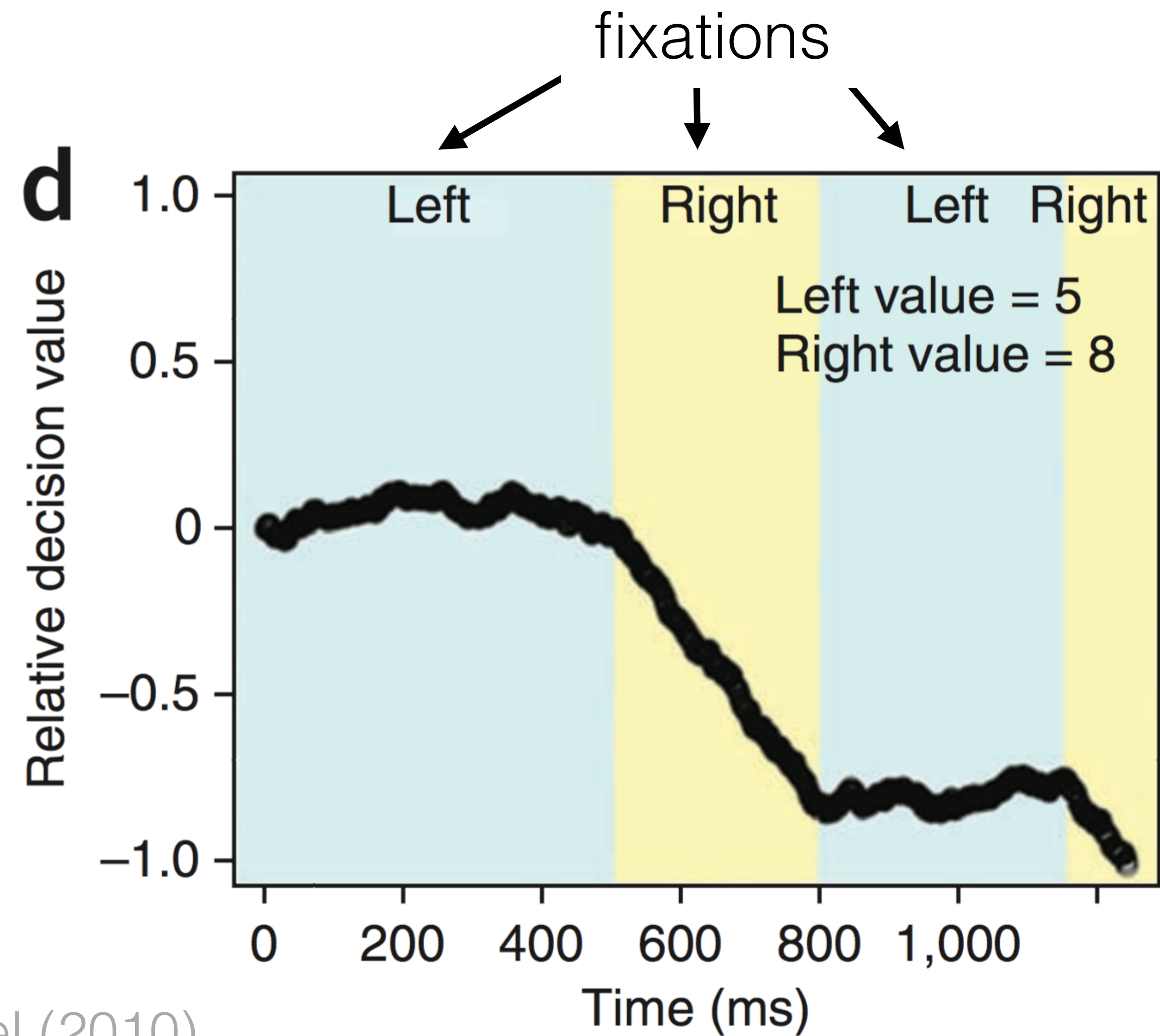

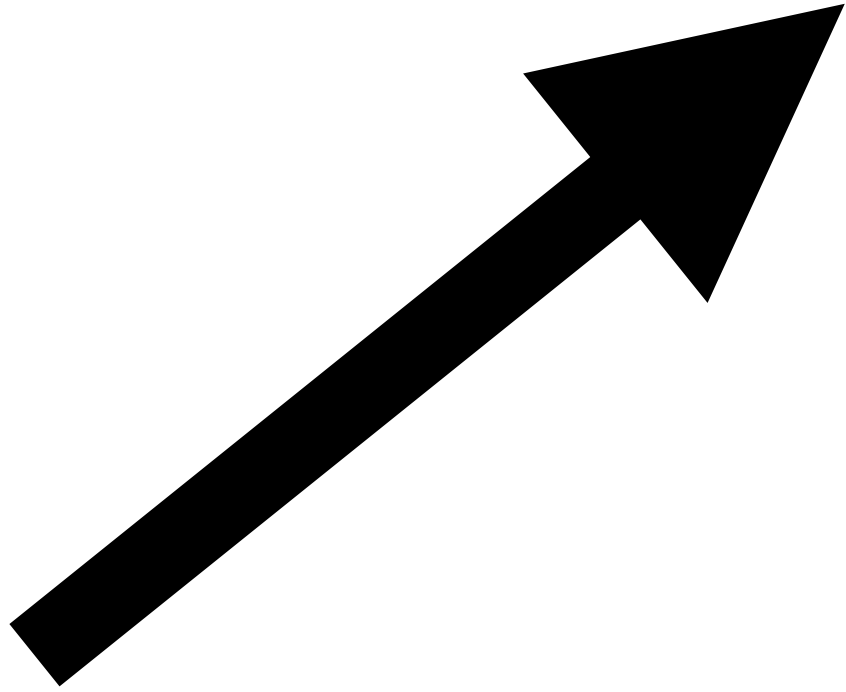
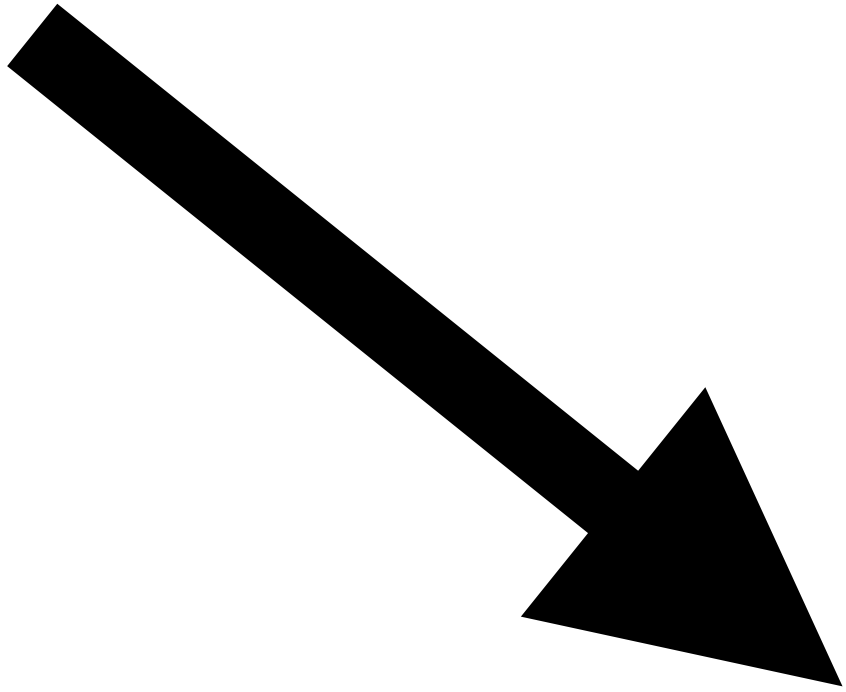
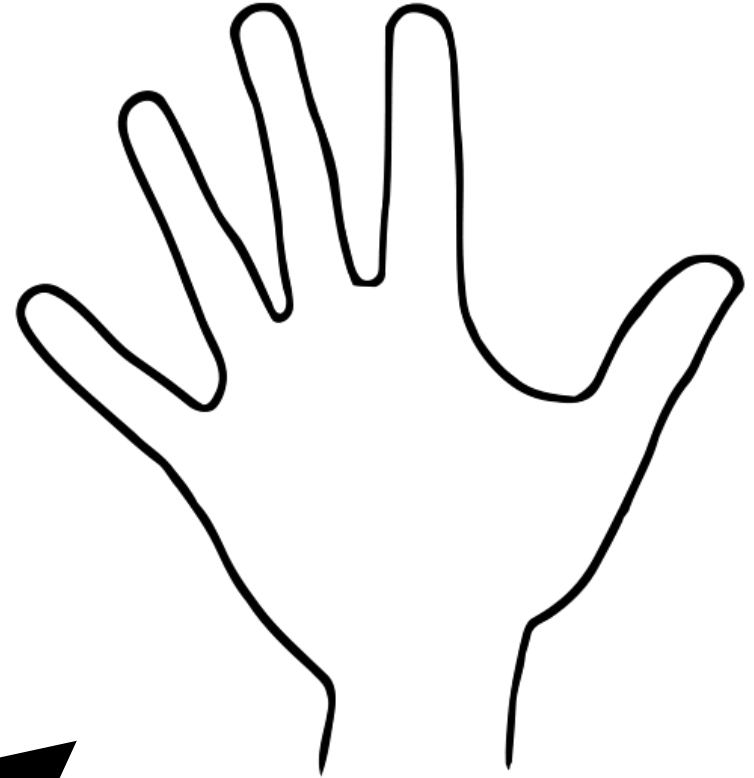
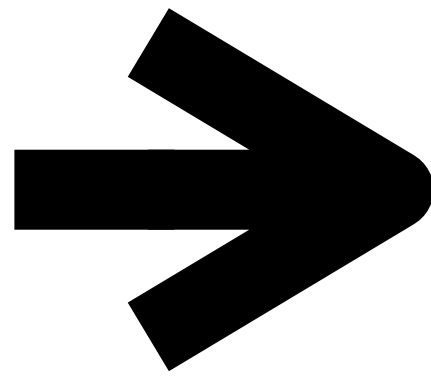
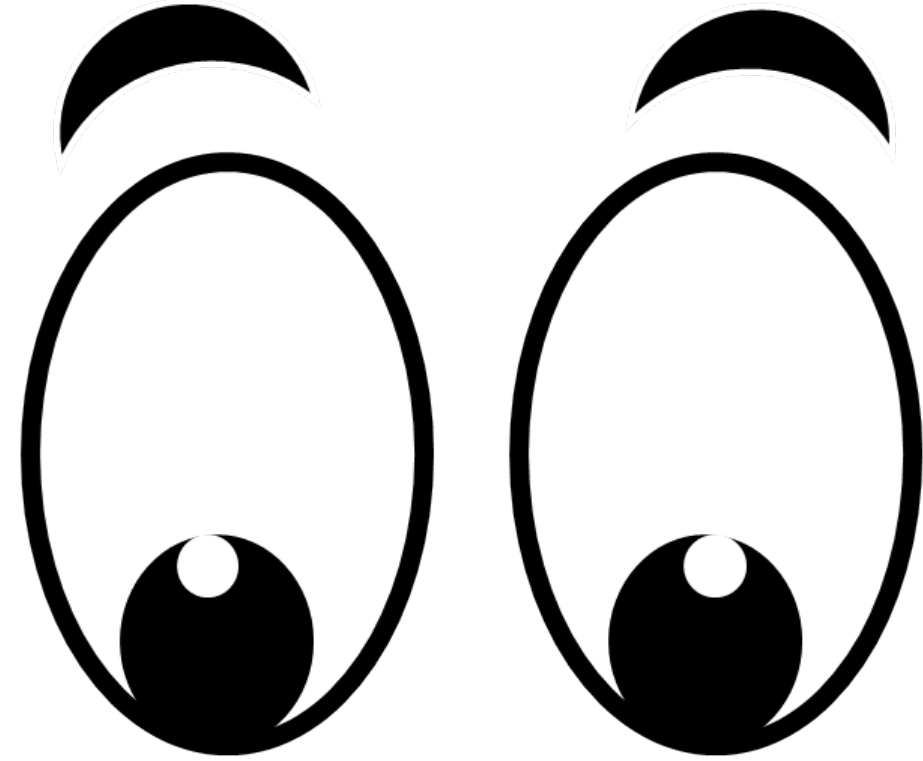

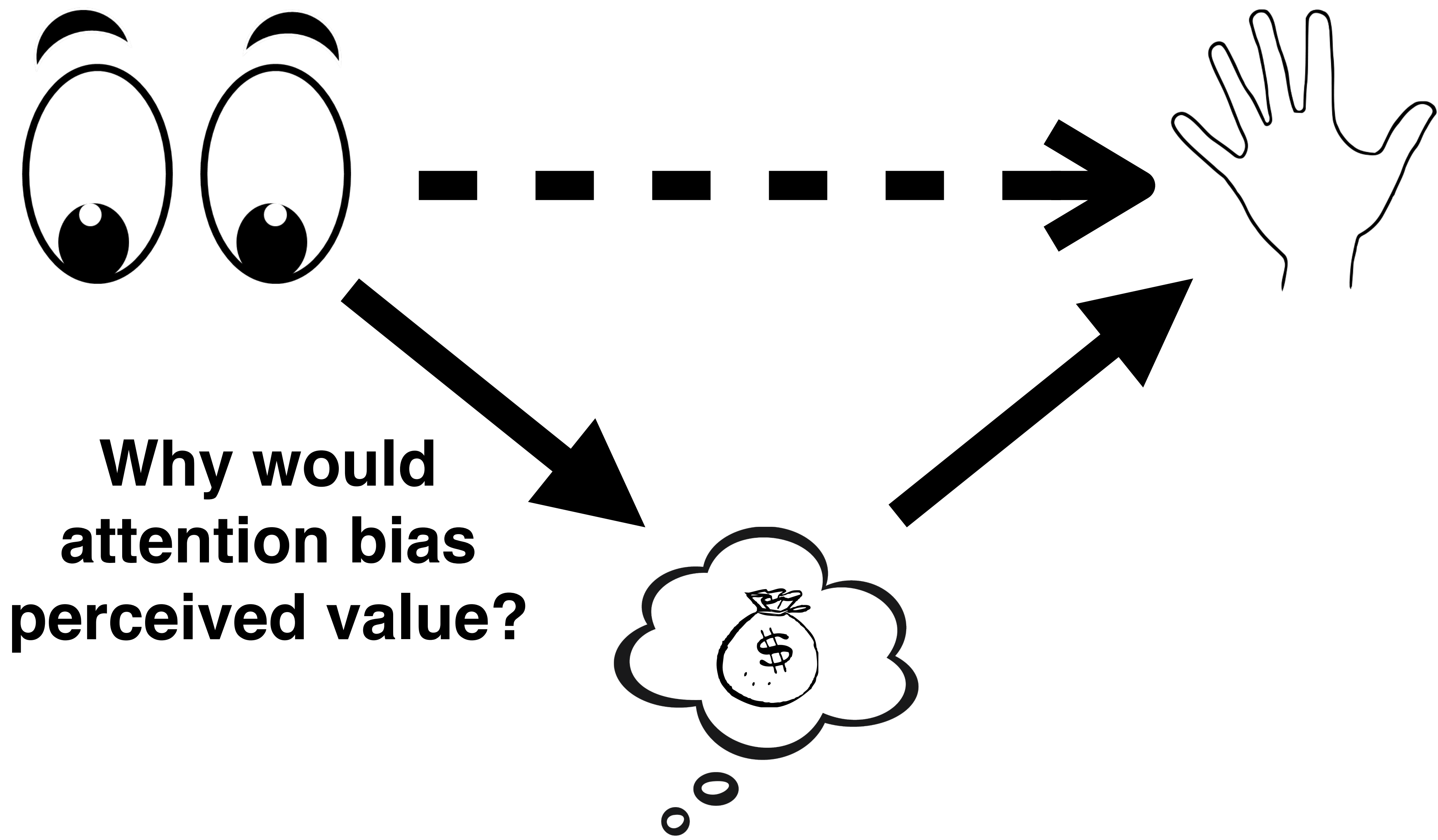

**Why would  
attention bias  
perceived value?**

**How do we choose  
what to look at?**

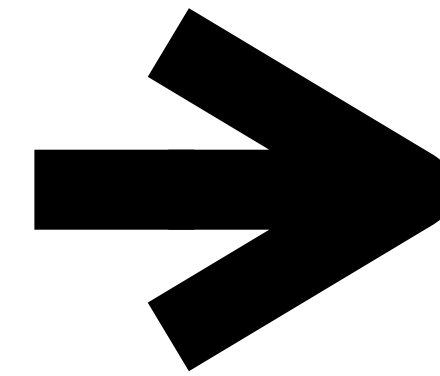
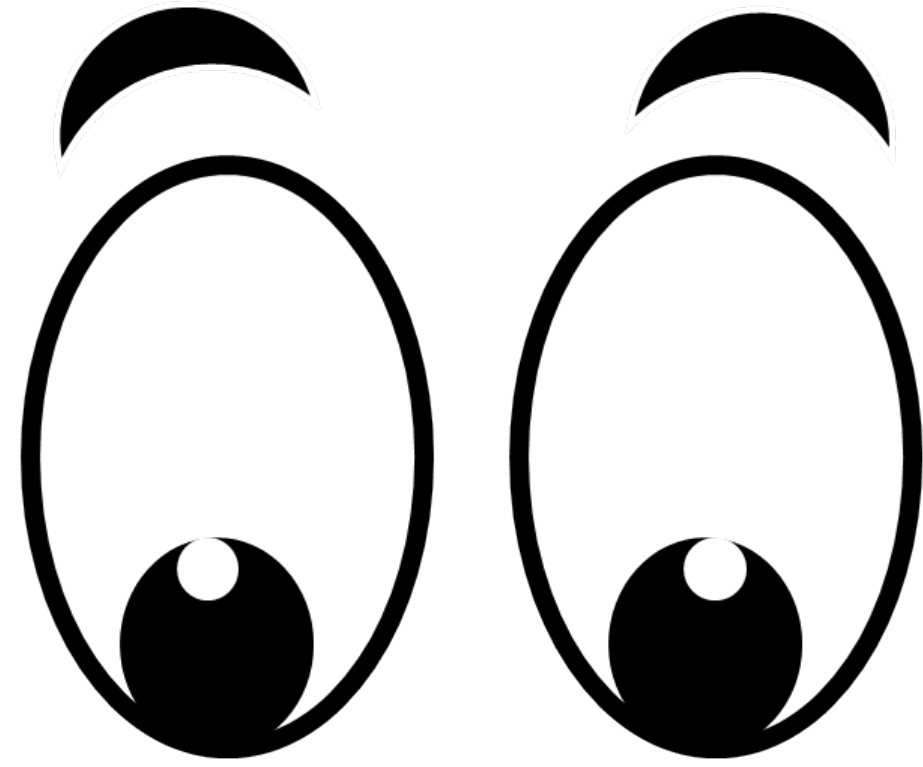

**Why would  
attention bias  
perceived value?**

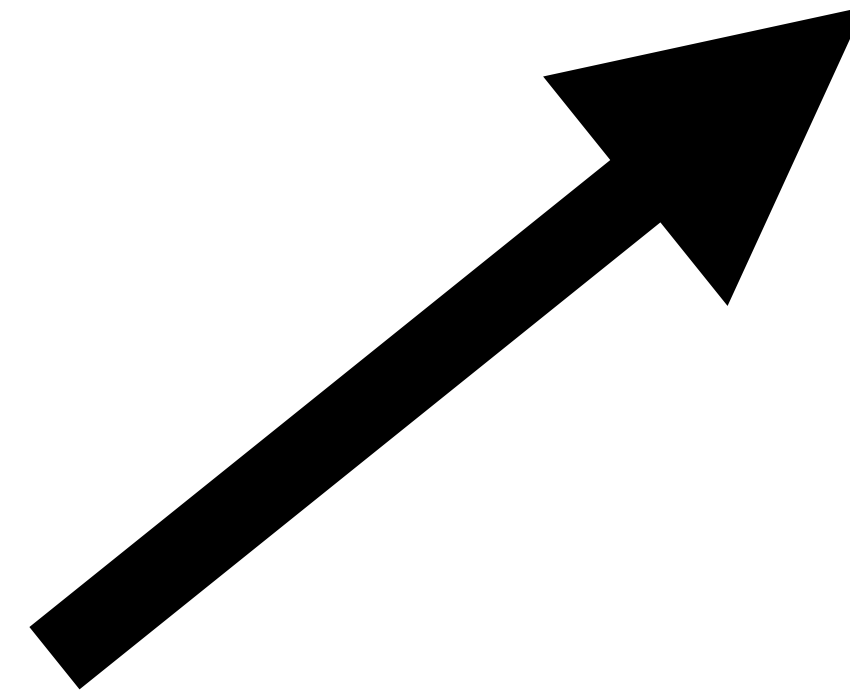
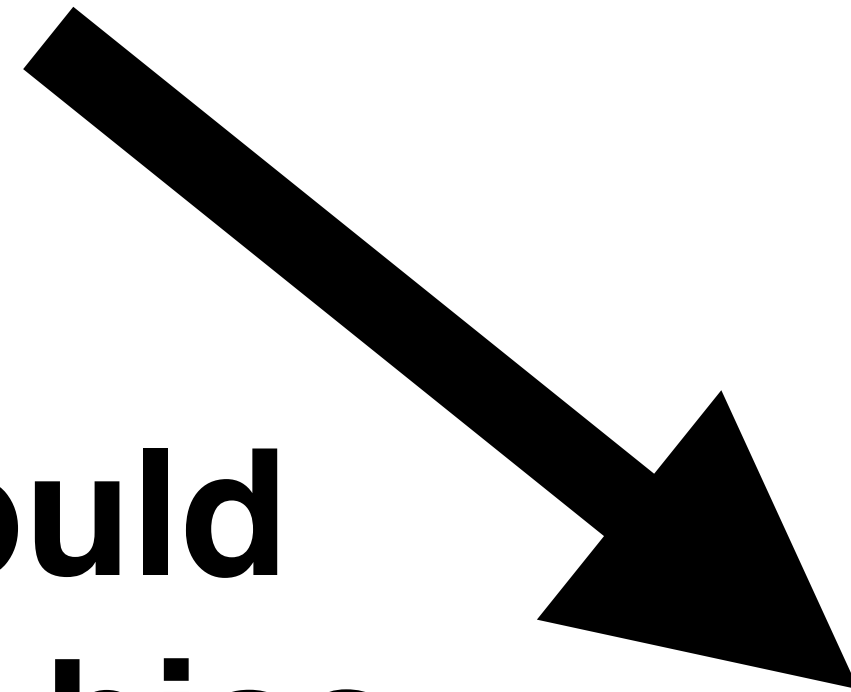



**How do we choose  
what to look at?**

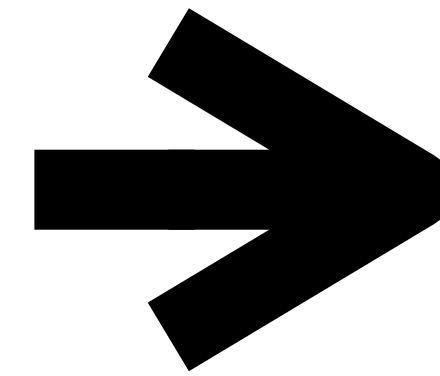
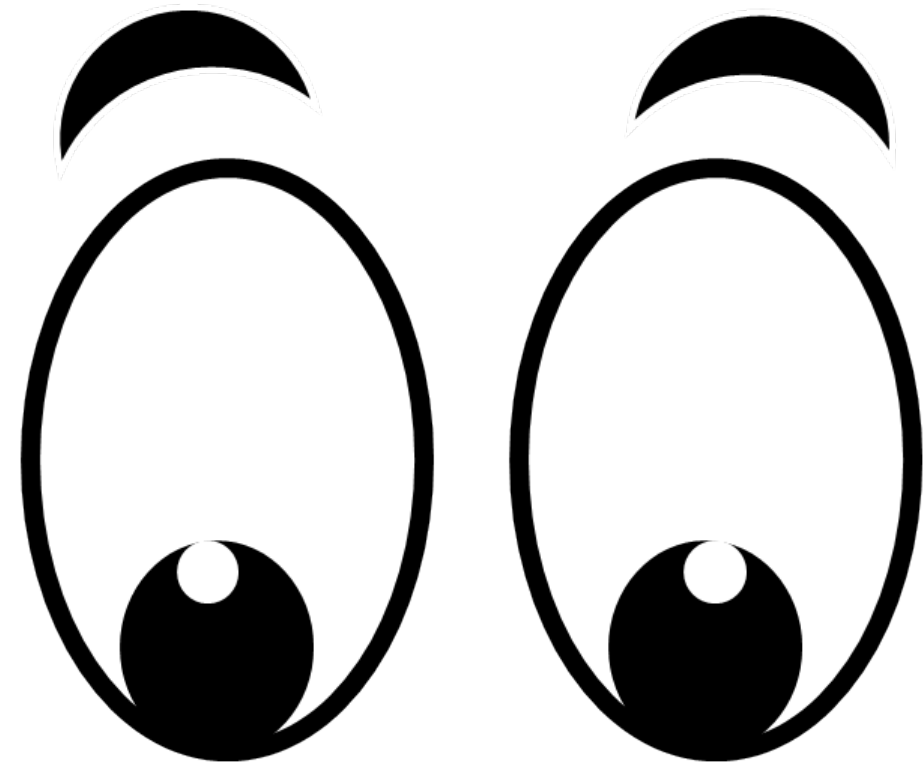

**Why would  
attention bias  
perceived value?**

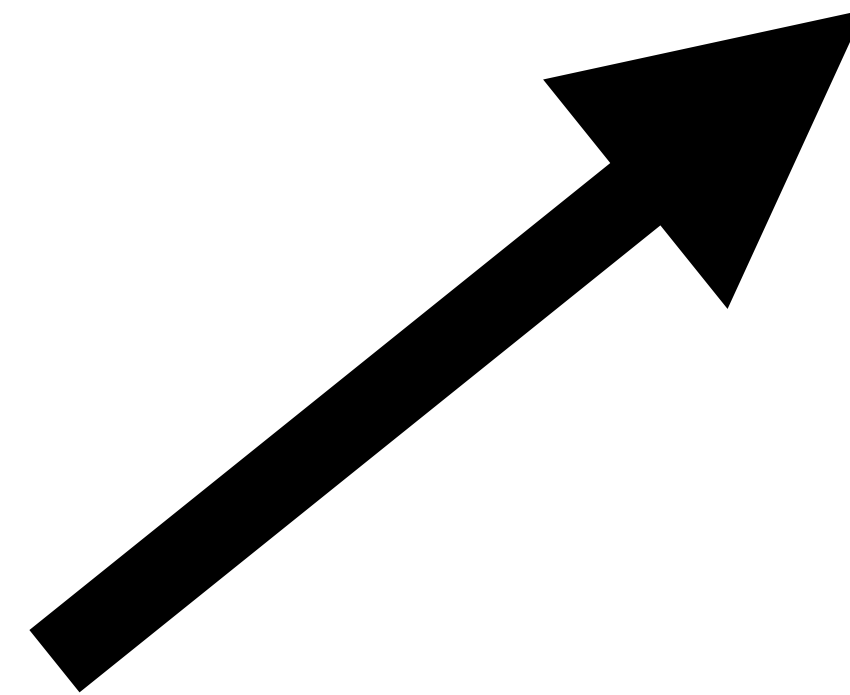
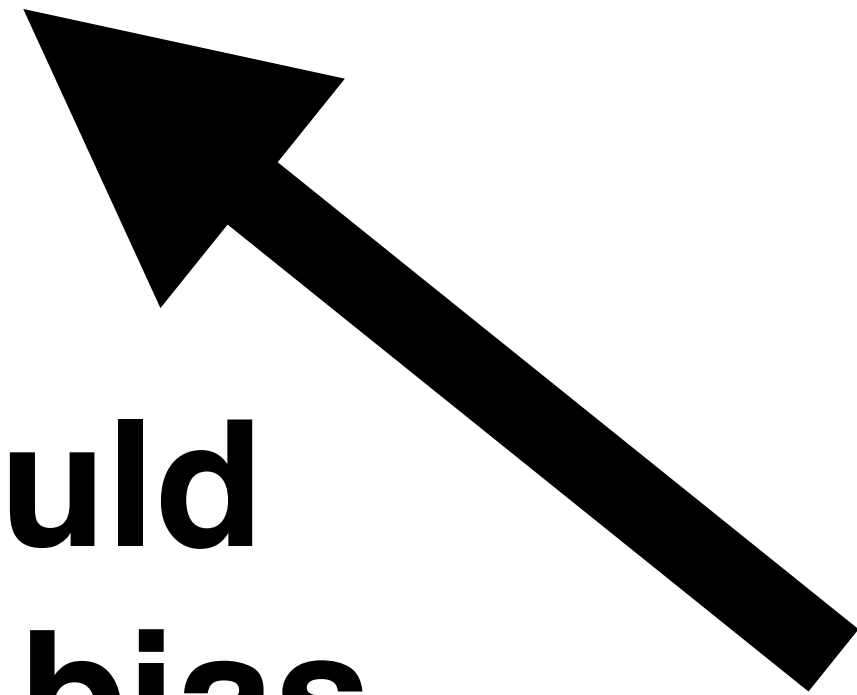

# Rational models of decision making

# Rational models of decision making

## **Expected utility theory**

- ▶ Take the action with maximal expected utility.

$$\arg \max_a \mathbb{E} [U(a)]$$

# Rational models of decision making

## Expected utility theory

- ▶ Take the action with maximal expected utility.

$$\arg \max_a \mathbb{E} [U(a)]$$

## Resource-rationality

- ▶ Use the *strategy* that best trades off utility and computational cost.

$$\arg \max_{\pi} \mathbb{E} \left[ \max_a \mathbb{E} [U(a) | B_T] - \sum_{t=0}^{T-1} \text{cost}(B_t, C_t) \mid C_t \sim \pi(B_t) \right]$$

# Rational models of decision making

## Expected utility theory

- ▶ Take the action with maximal expected utility.

$$\arg \max_a \mathbb{E} [U(a)]$$

“Do the right thing.”

## Resource-rationality

- ▶ Use the *strategy* that best trades off utility and computational cost.

$$\arg \max_{\pi} \mathbb{E} \left[ \max_a \mathbb{E} [U(a) | B_T] - \sum_{t=0}^{T-1} \text{cost}(B_t, C_t) \mid C_t \sim \pi(B_t) \right]$$

# Rational models of decision making

## Expected utility theory

- ▶ Take the action with maximal expected utility.

$$\arg \max_a \mathbb{E} [U(a)]$$

“Do the right thing.”

## Resource-rationality

- ▶ Use the *strategy* that best trades off utility and computational cost.

$$\arg \max_{\pi} \mathbb{E} \left[ \max_a \mathbb{E} [U(a) | B_T] - \sum_{t=0}^{T-1} \text{cost}(B_t, C_t) \mid C_t \sim \pi(B_t) \right]$$

“Do the right *thinking*.”

How can we model the right thinking?

How can we model the right thinking?

**Key Intuition**

*Thinking is a sequential  
decision problem.*



# How can we model the right thinking?

## ***Metalevel* Markov decision process**

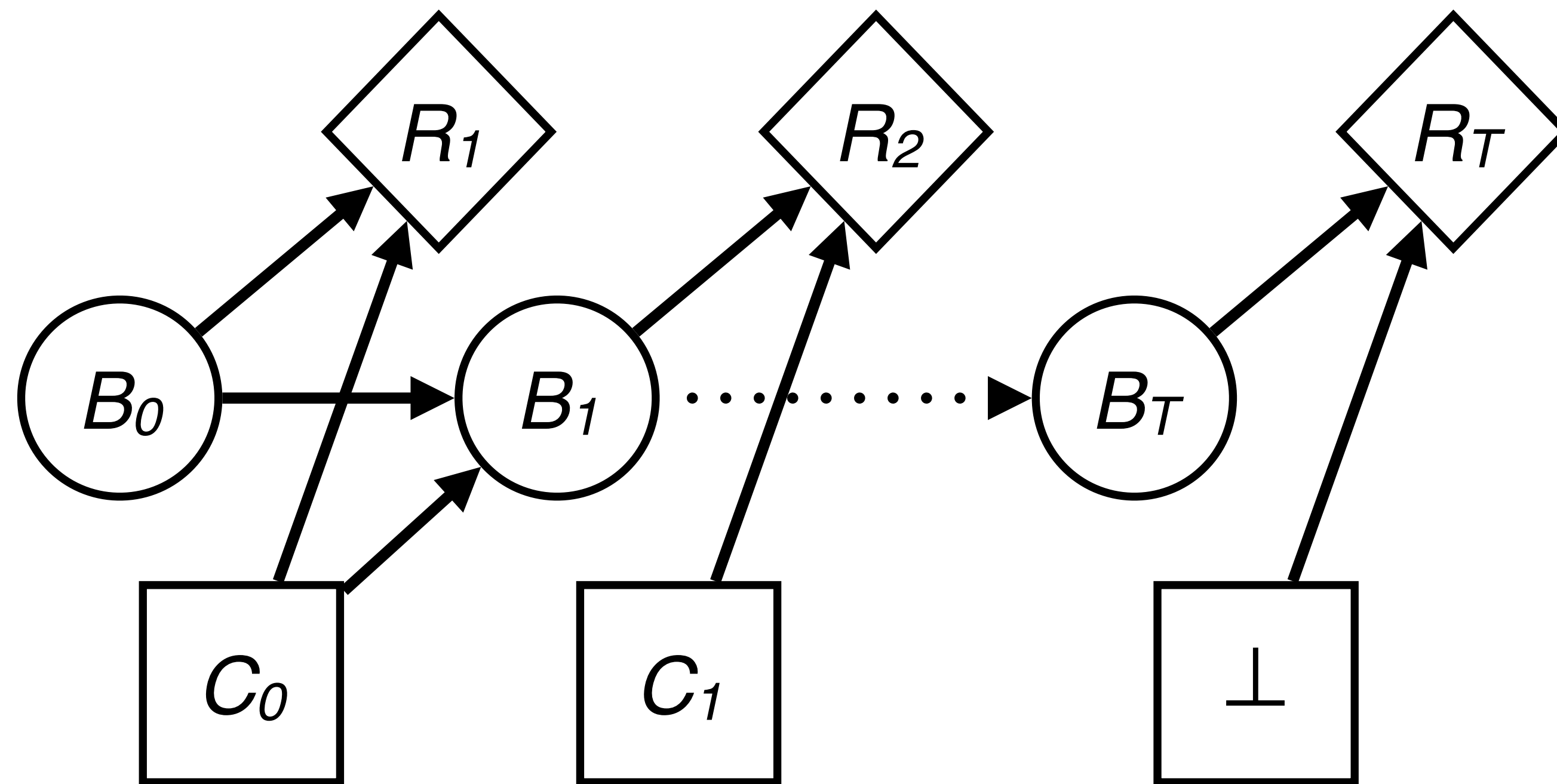

# How can we model the right thinking?

## ***Metalevel* Markov decision process**

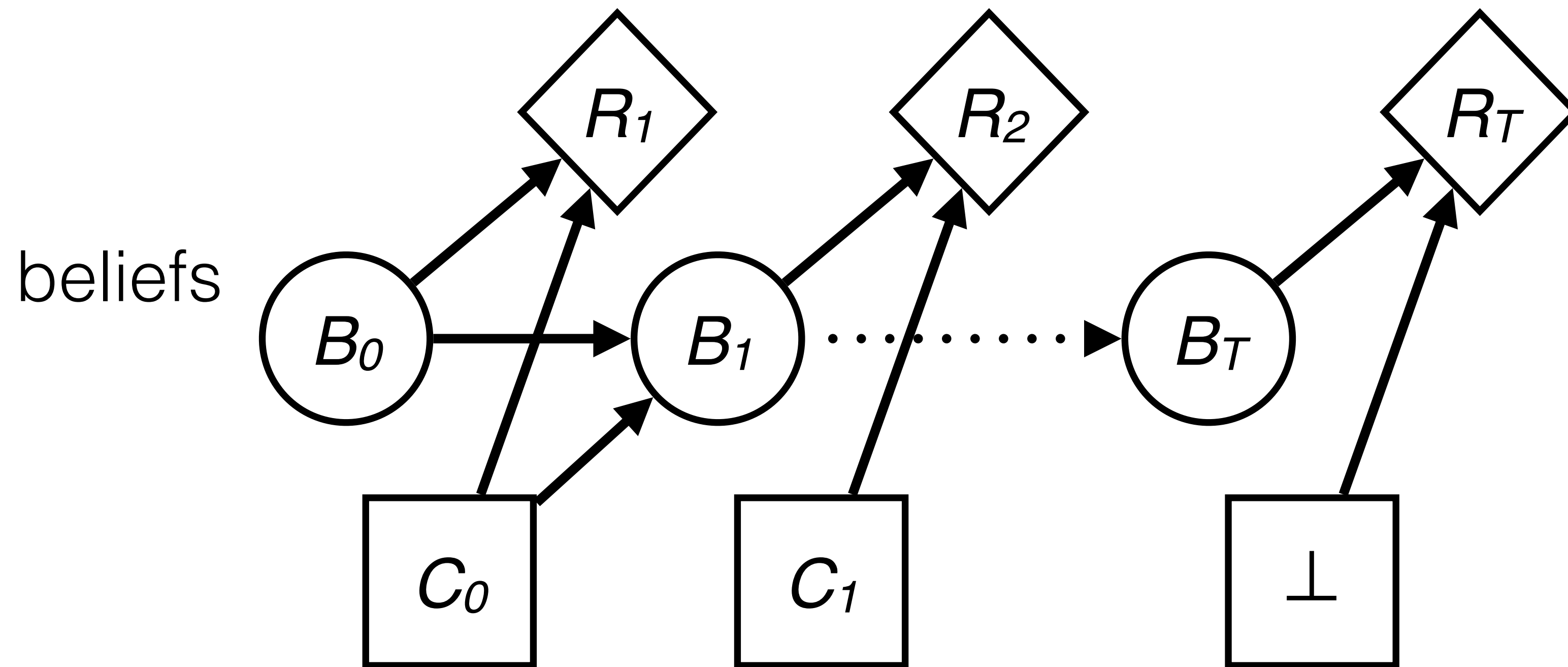

# How can we model the right thinking?

## ***Metalevel* Markov decision process**

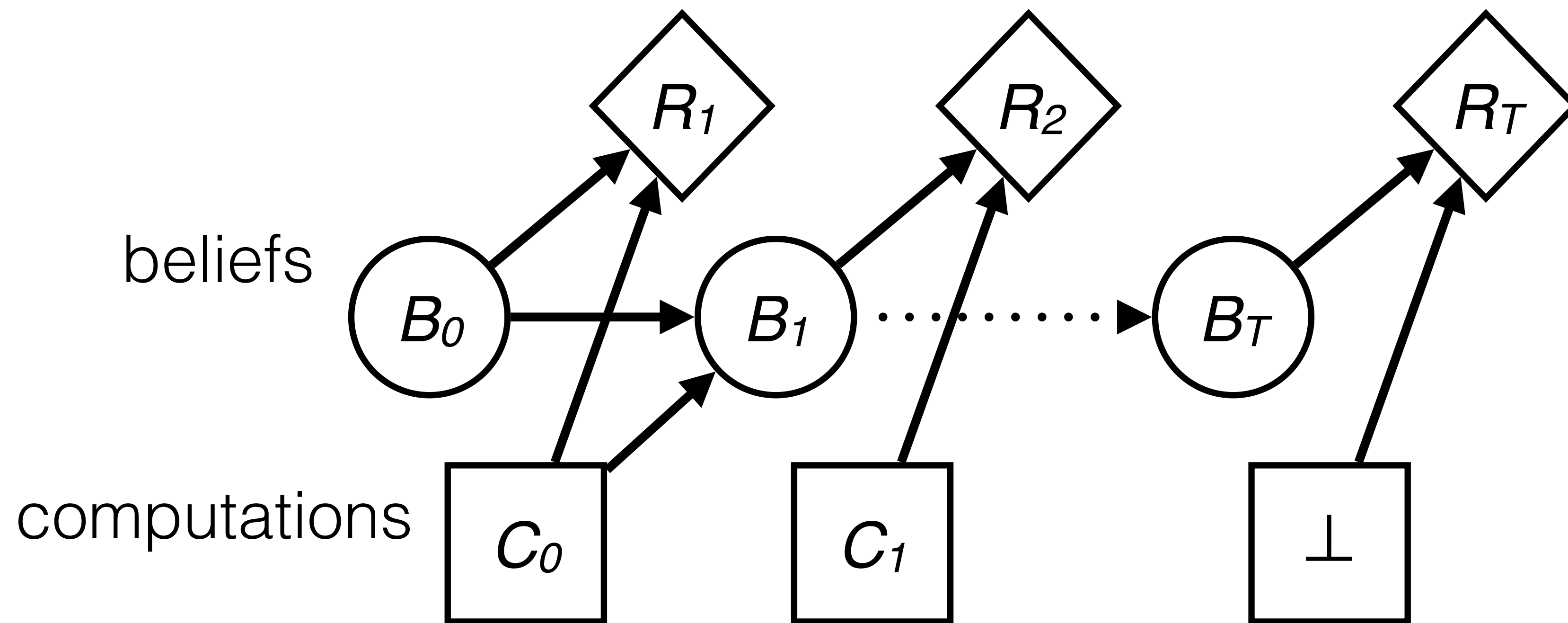

# How can we model the right thinking?

## ***Metalevel* Markov decision process**

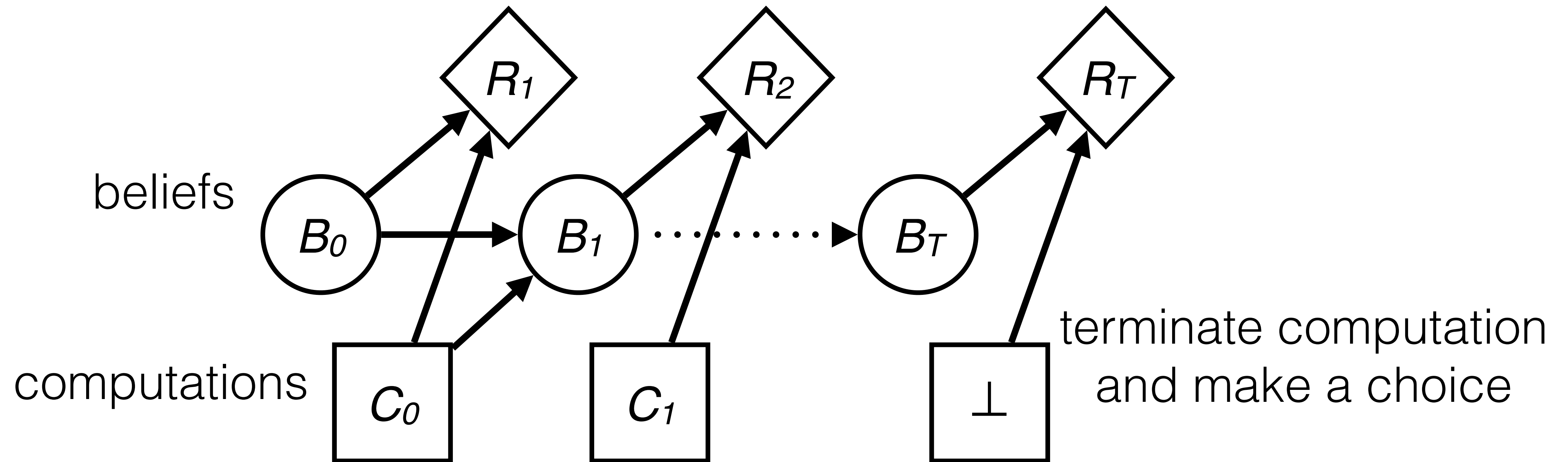

# How can we model the right thinking?

## ***Metalevel* Markov decision process**

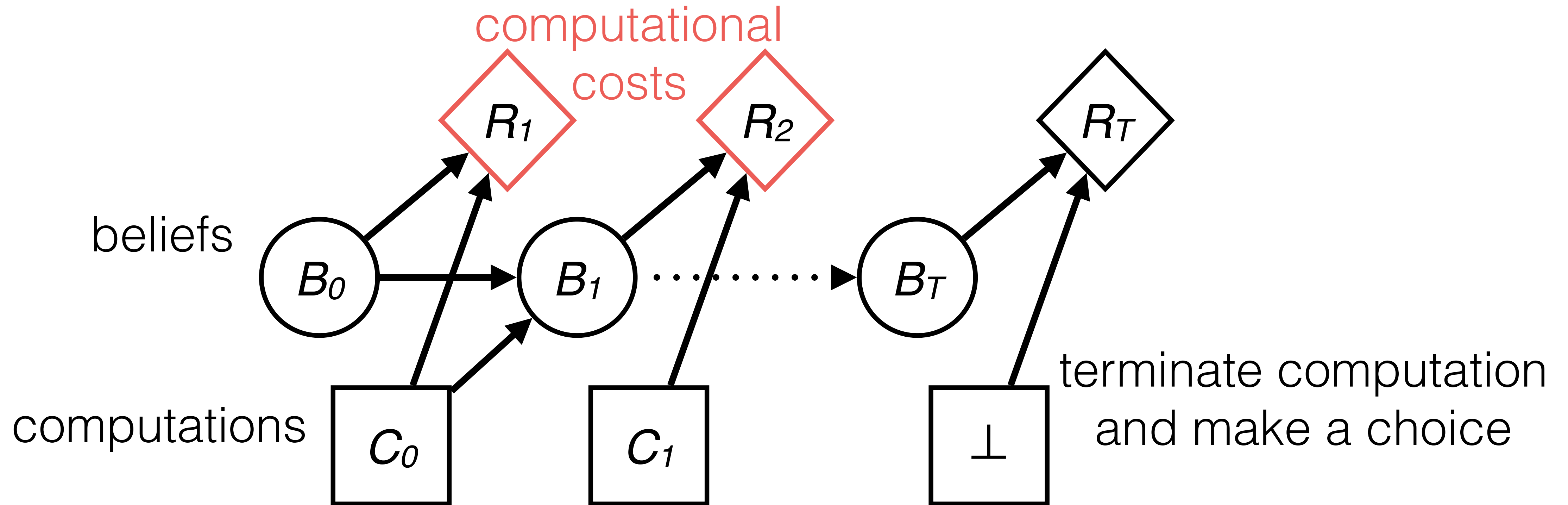

# How can we model the right thinking?

## ***Metalevel* Markov decision process**

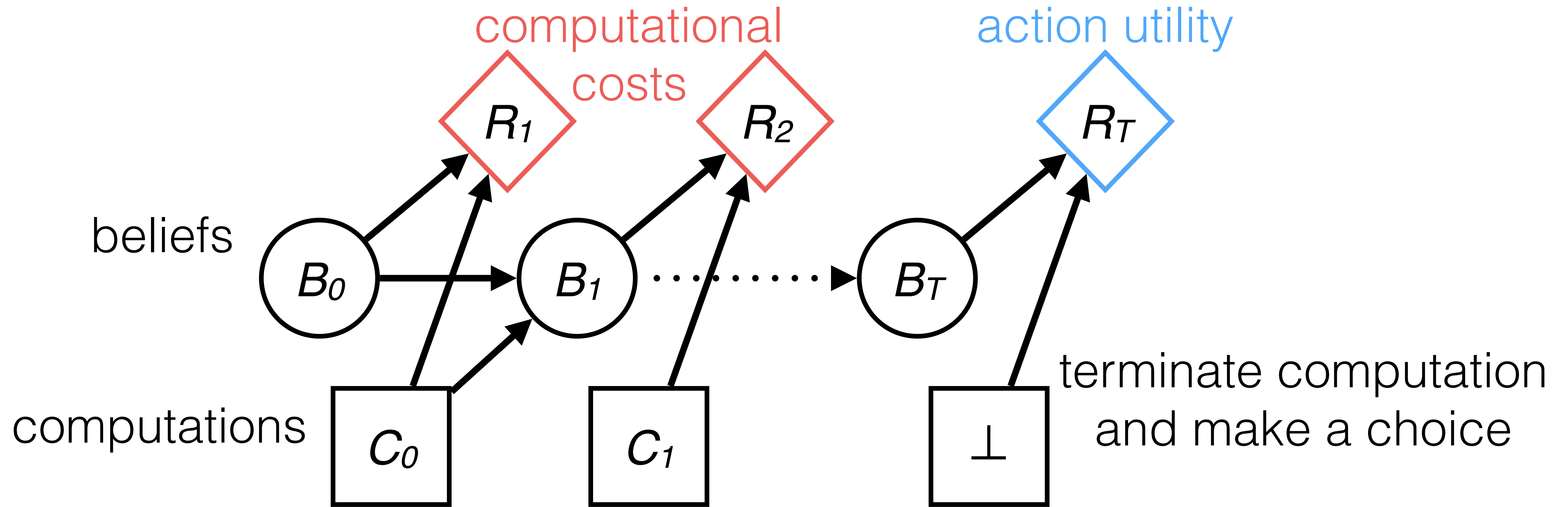

# How can we model the right thinking?

## ***Metalevel* Markov decision process**

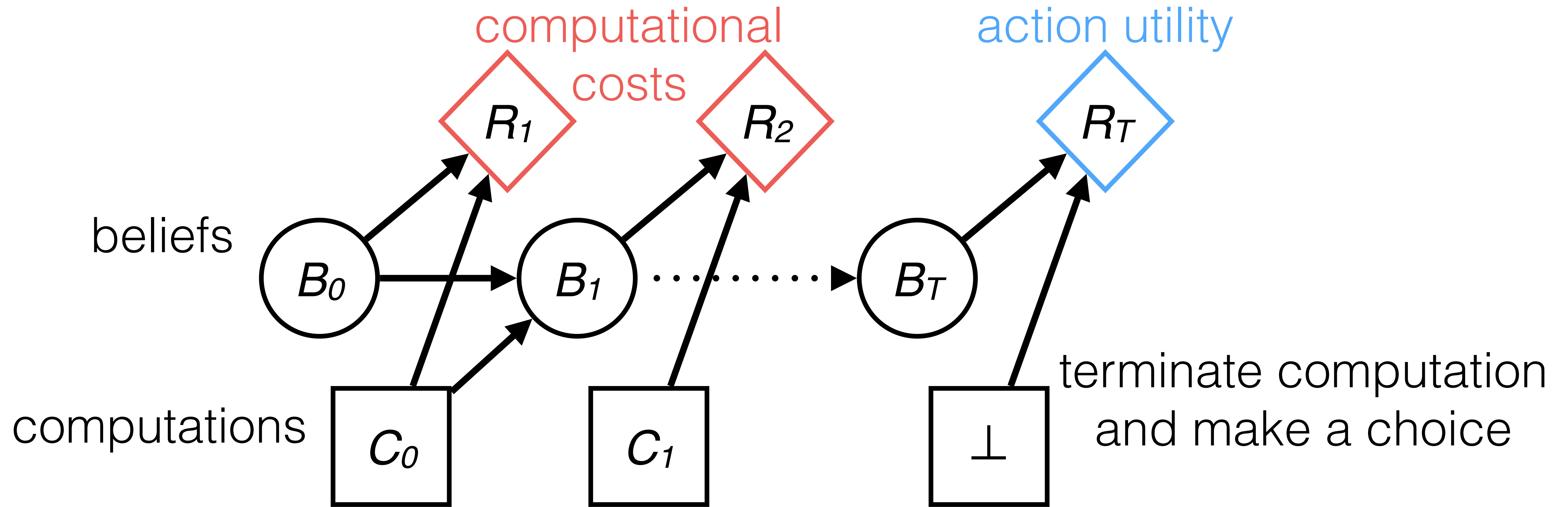

Hay et al. (2012)

$$\arg \max_{\pi} \mathbb{E} \left[ \underbrace{\max_a \mathbb{E} [U(a) | B_T]}_{\text{action utility}} - \underbrace{\sum_{t=0}^{T-1} \text{cost}(B_t, C_t)}_{\text{computational costs}} \mid C_t \sim \pi(B_t) \right]$$







$B_0$

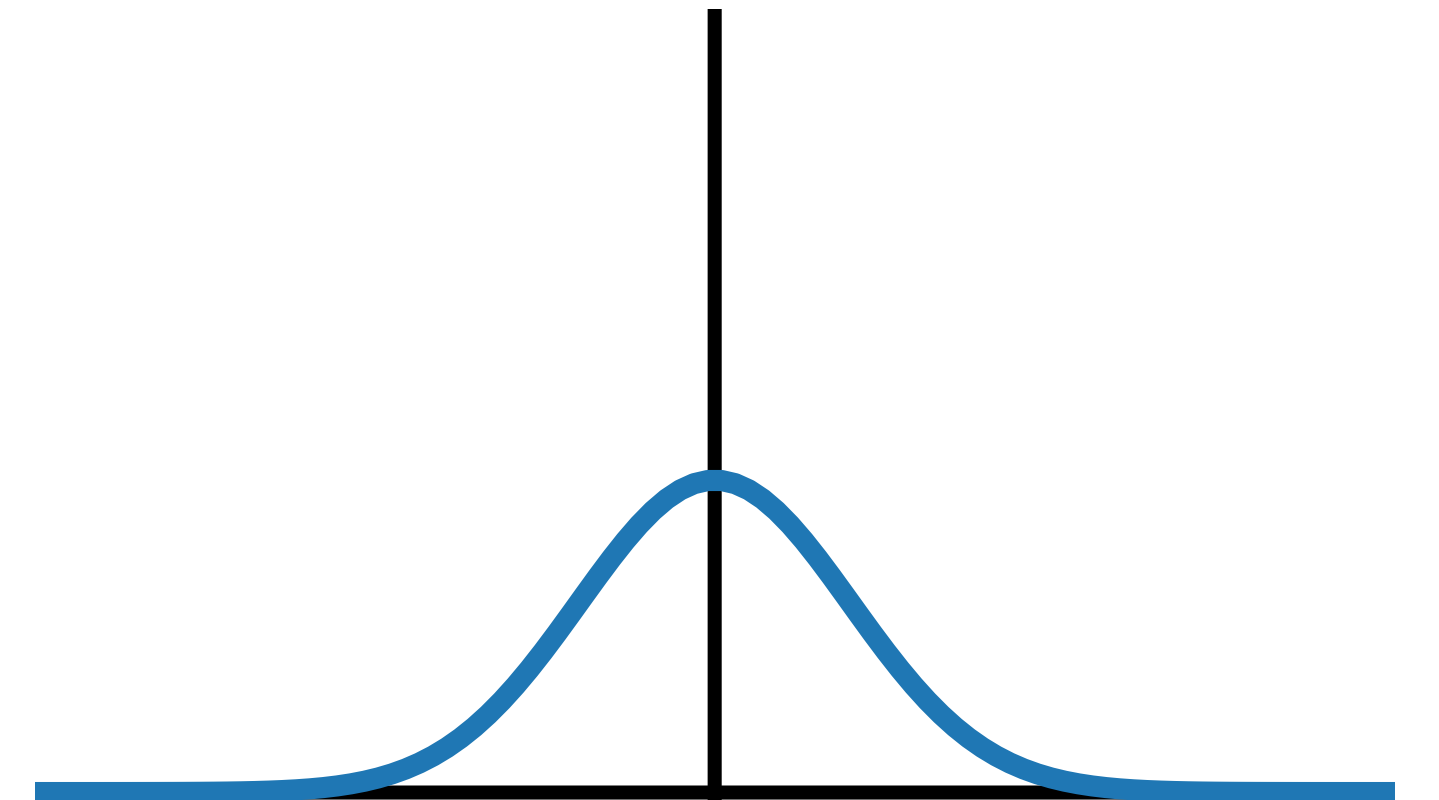
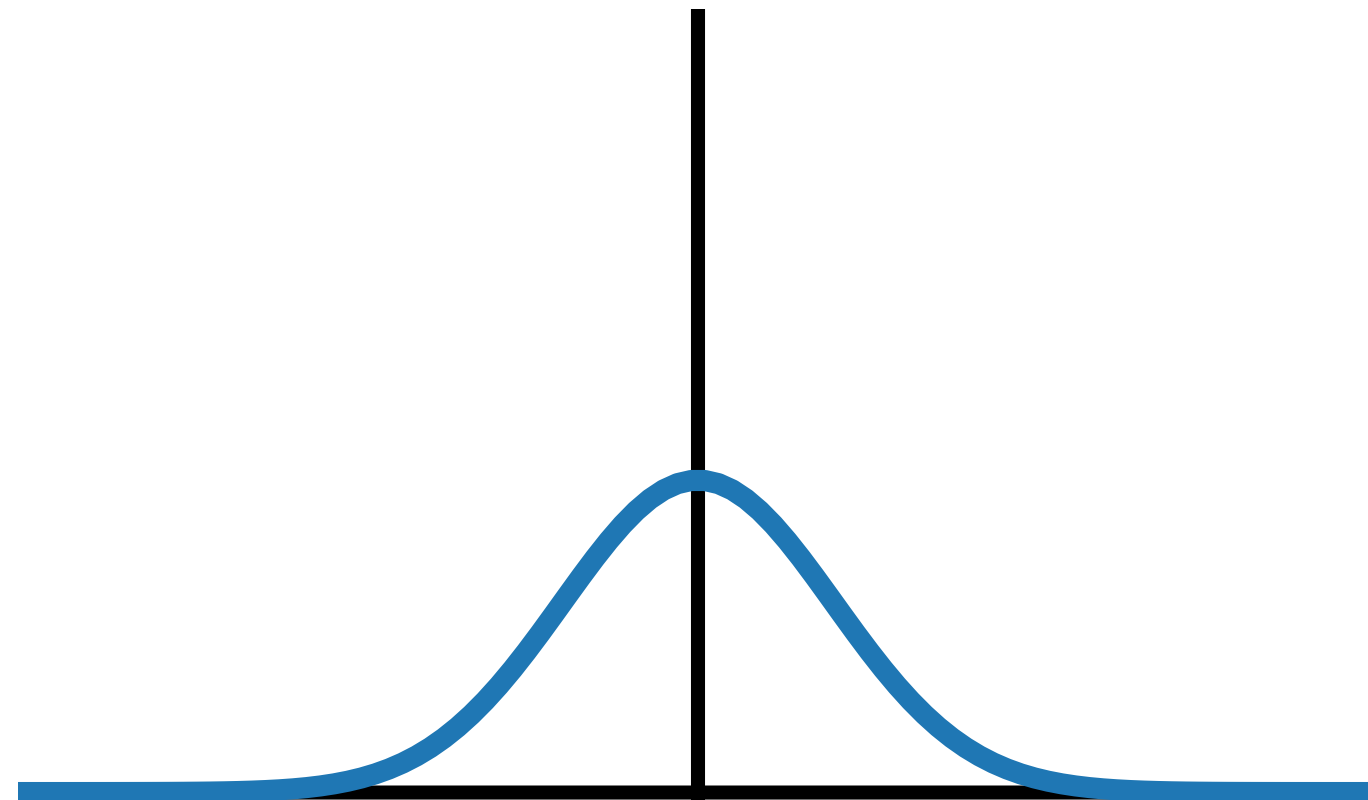
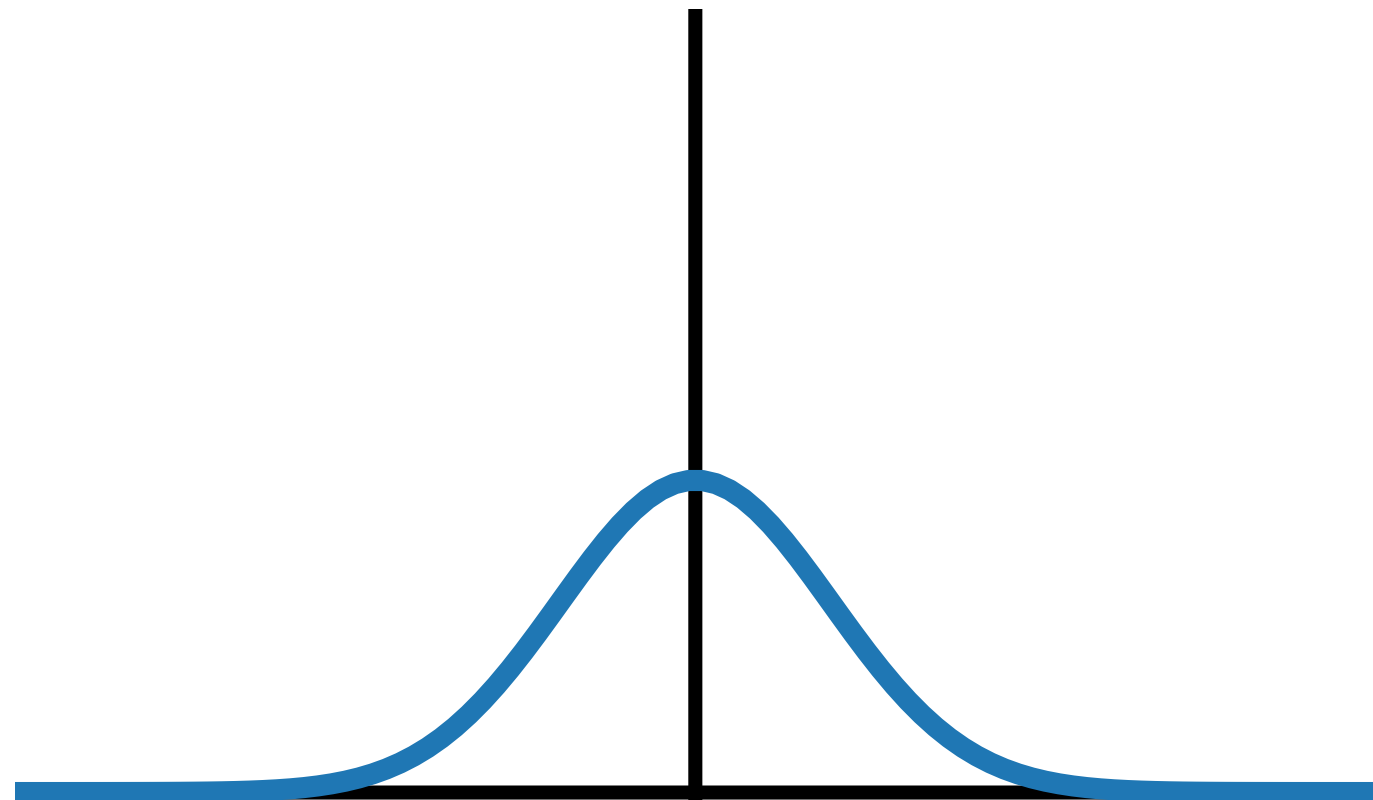



$B_0$

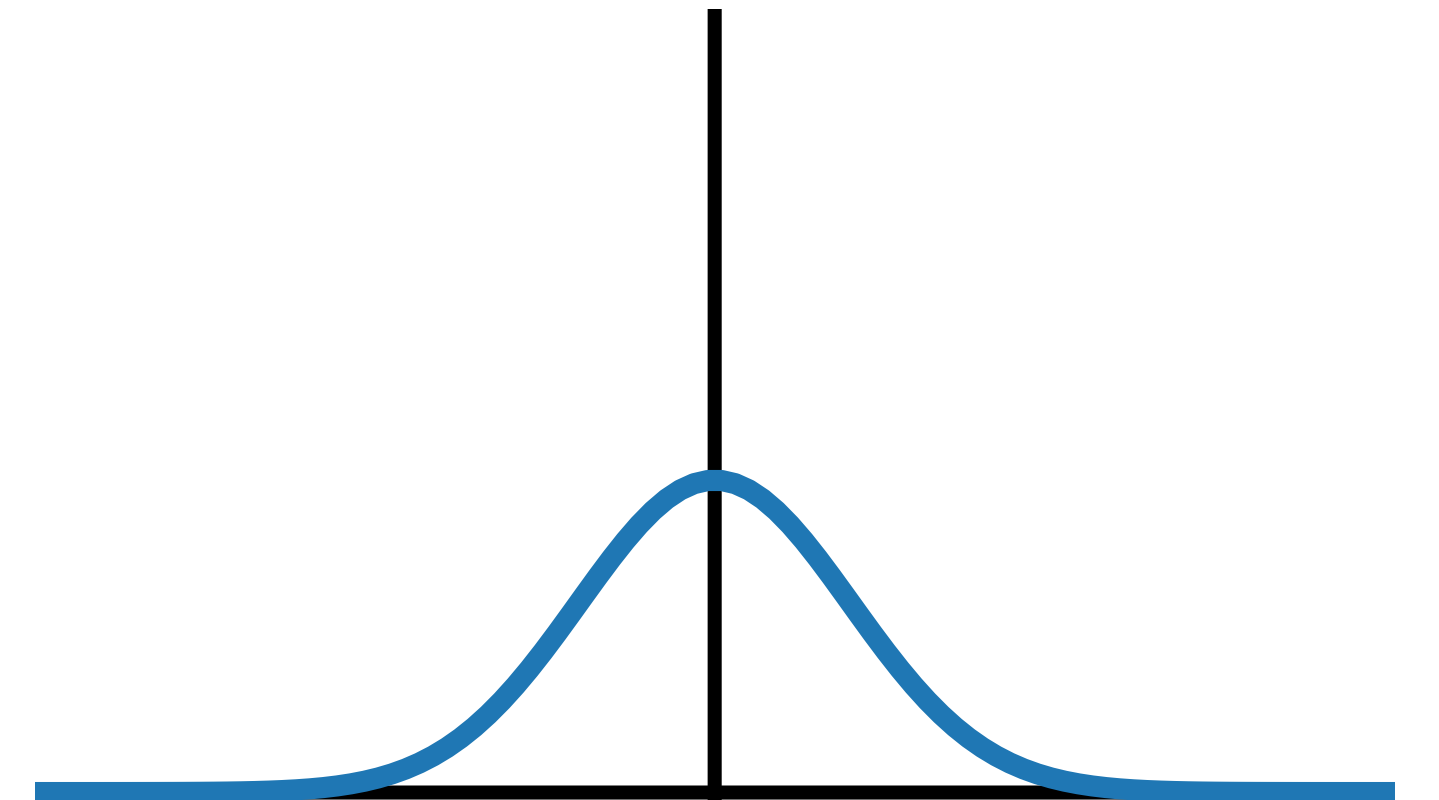
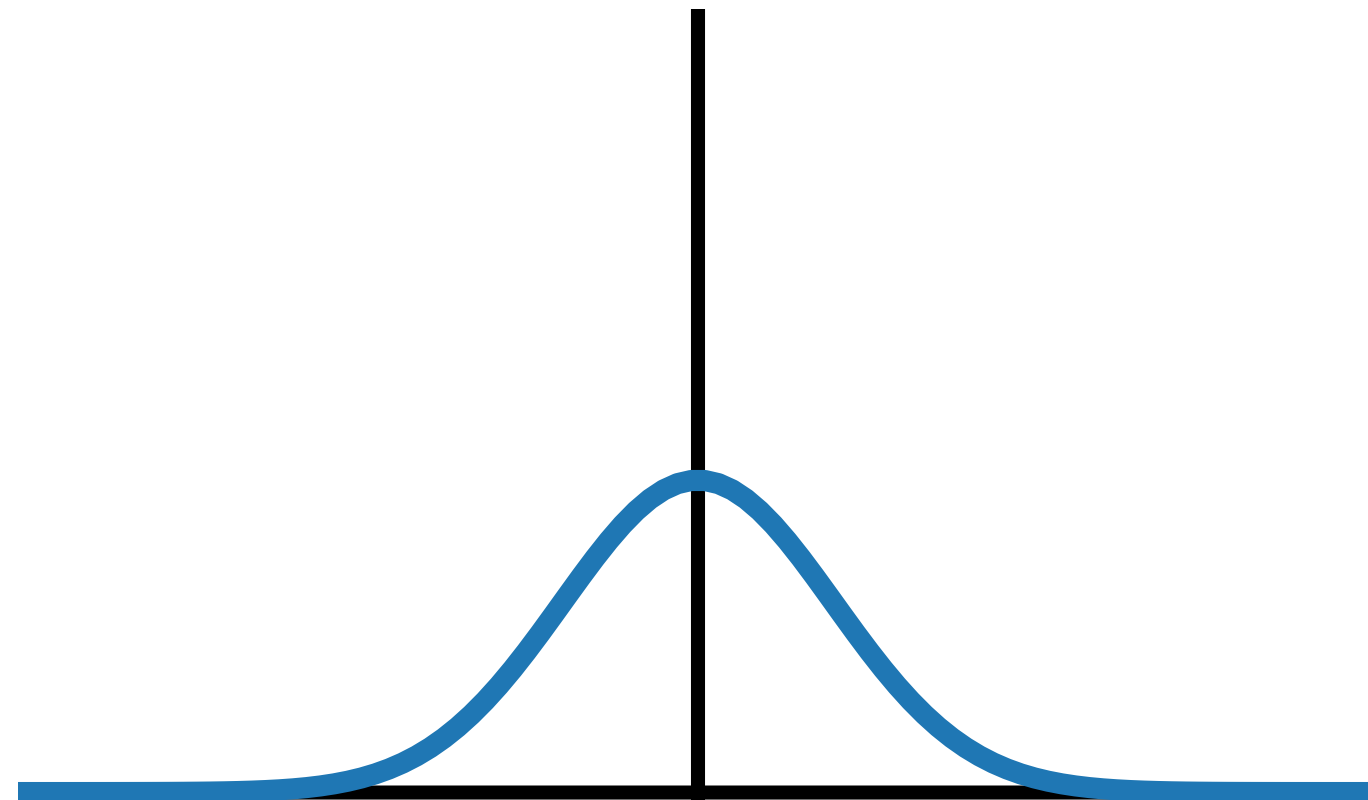
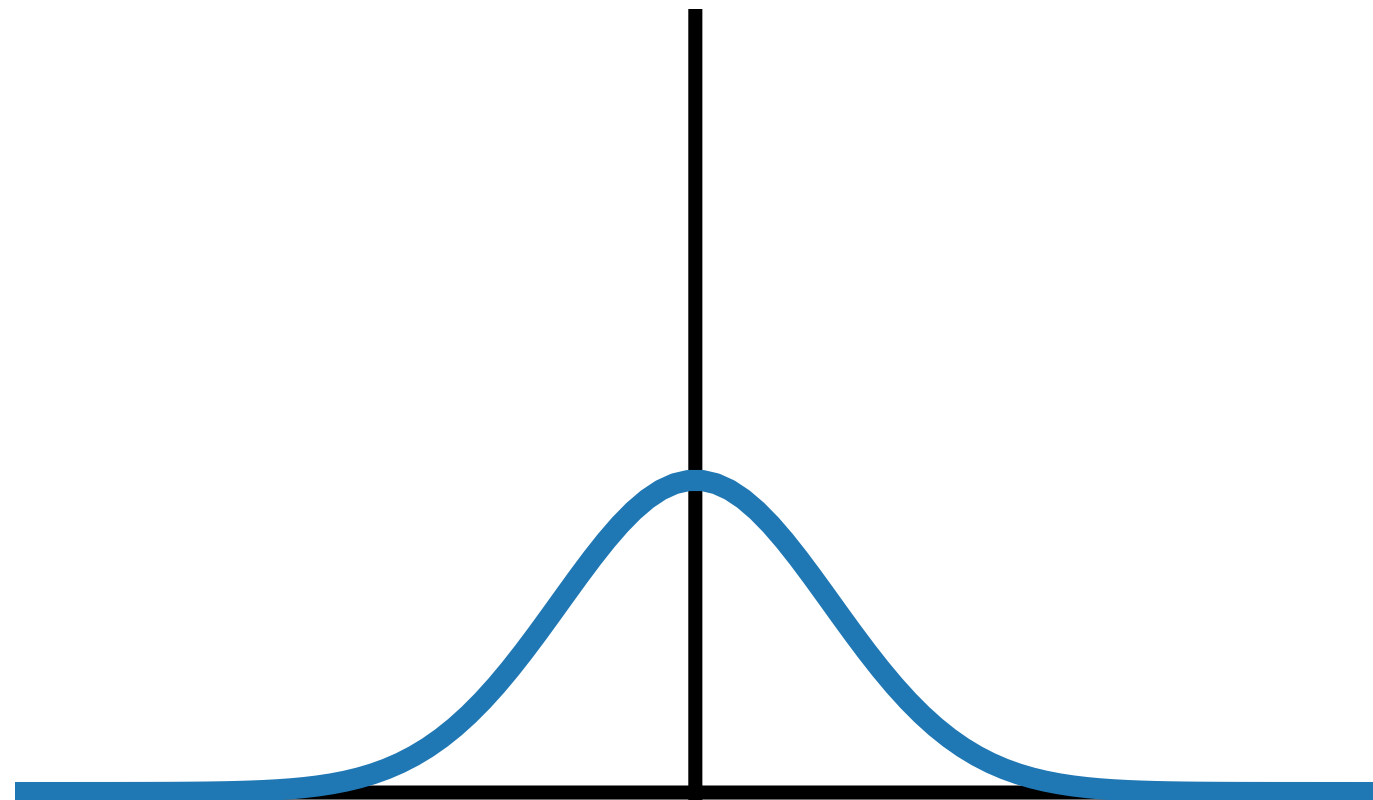
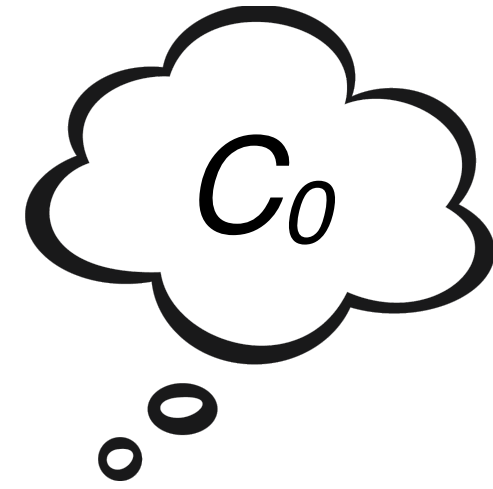



$B_0$

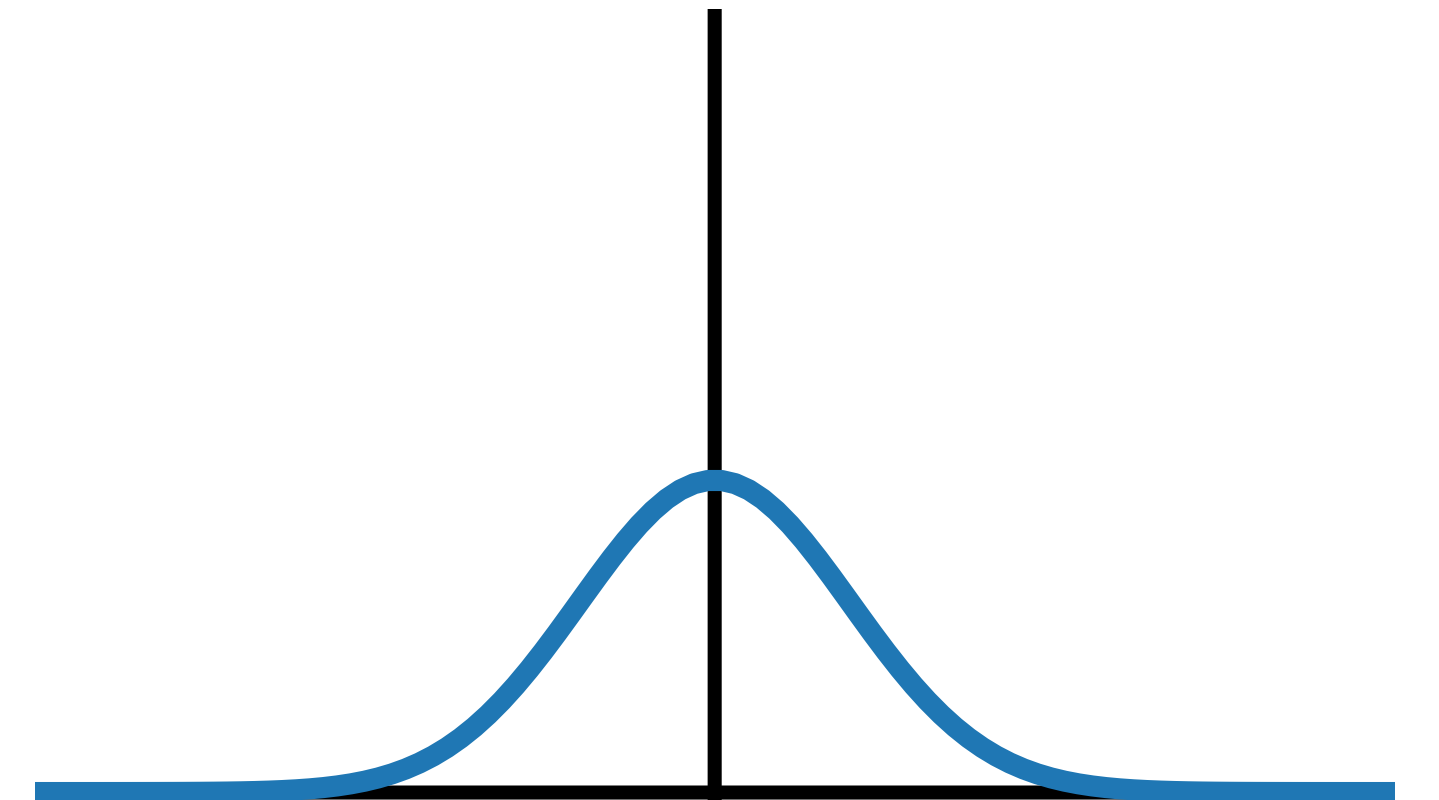
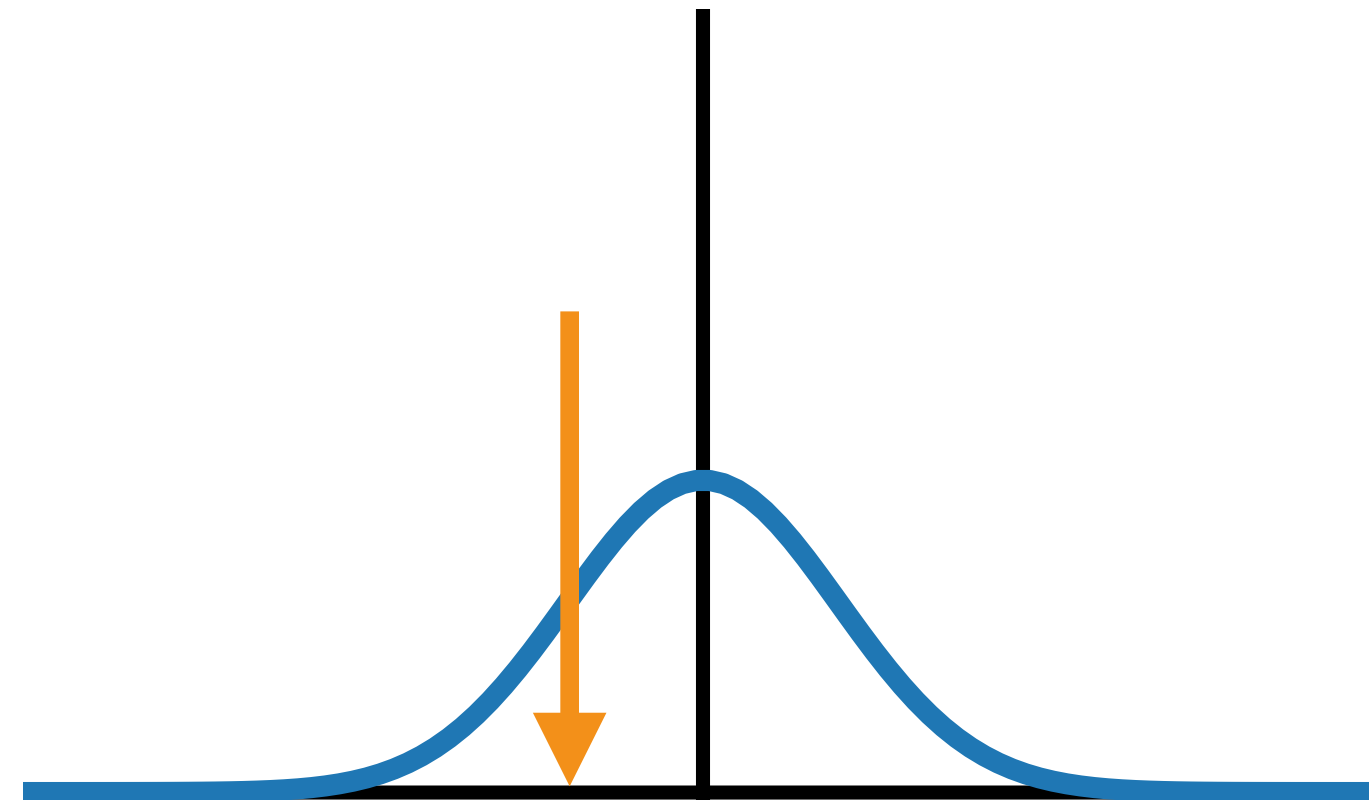
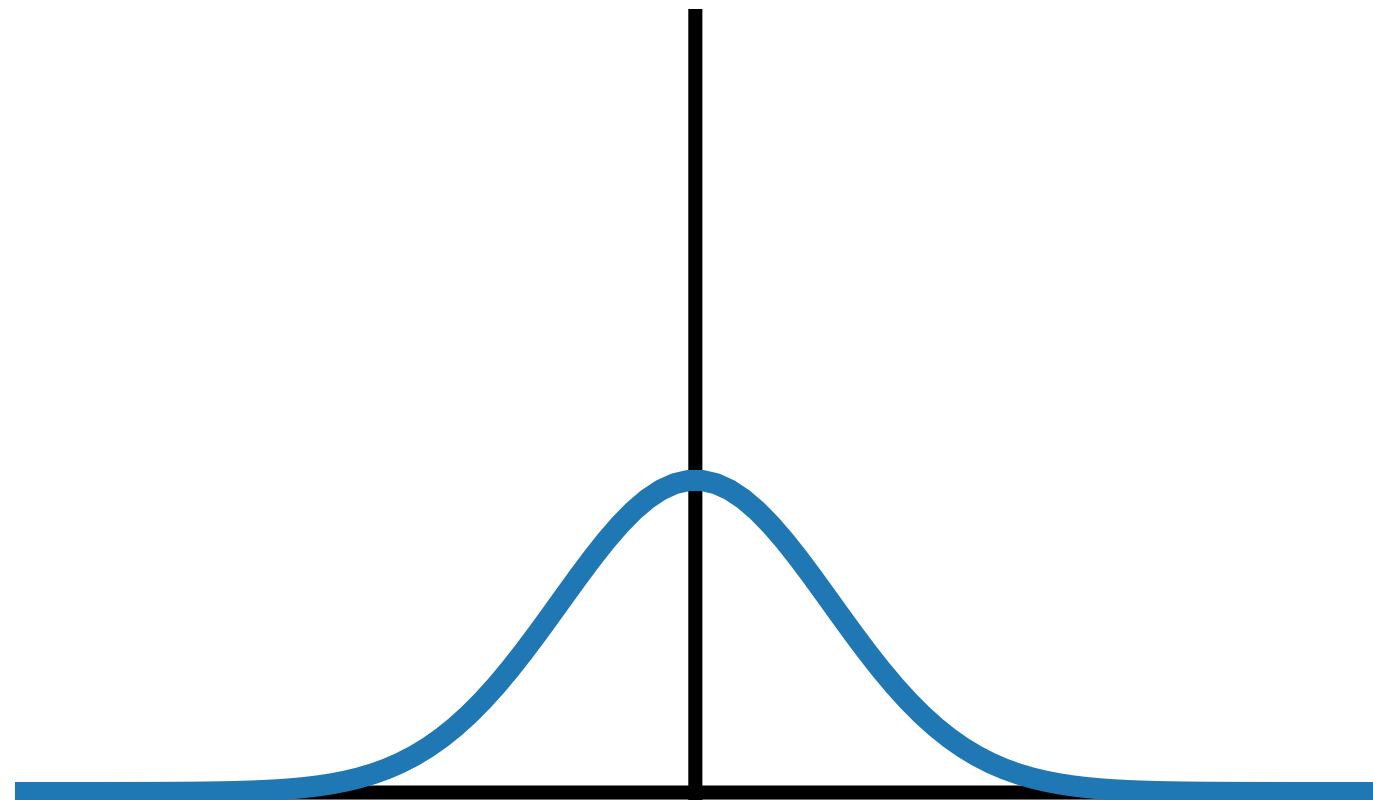
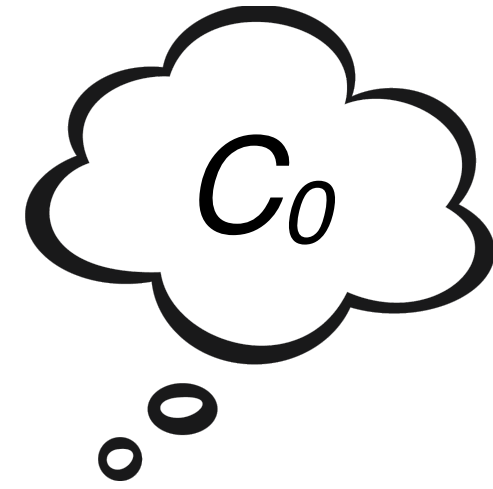



$B_1$

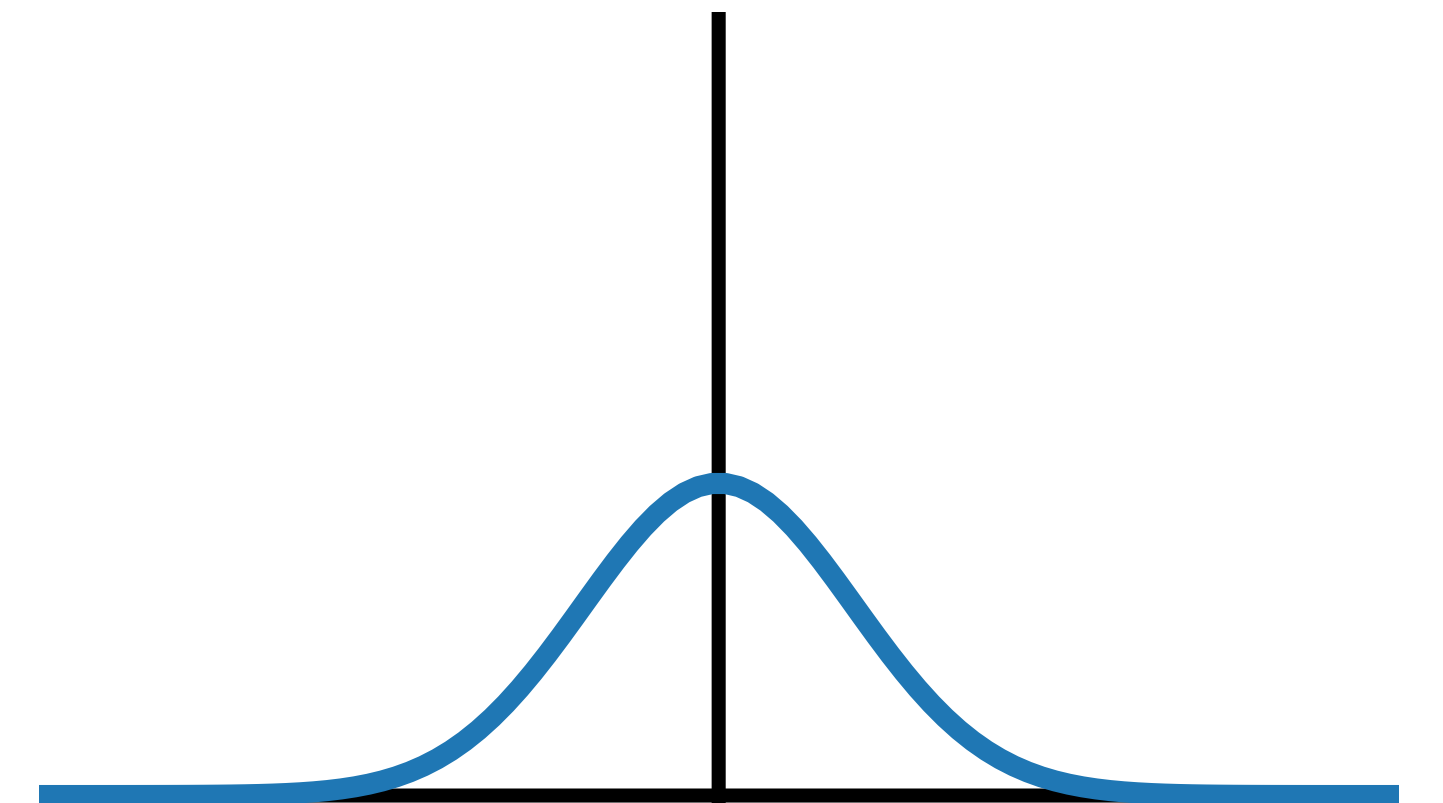
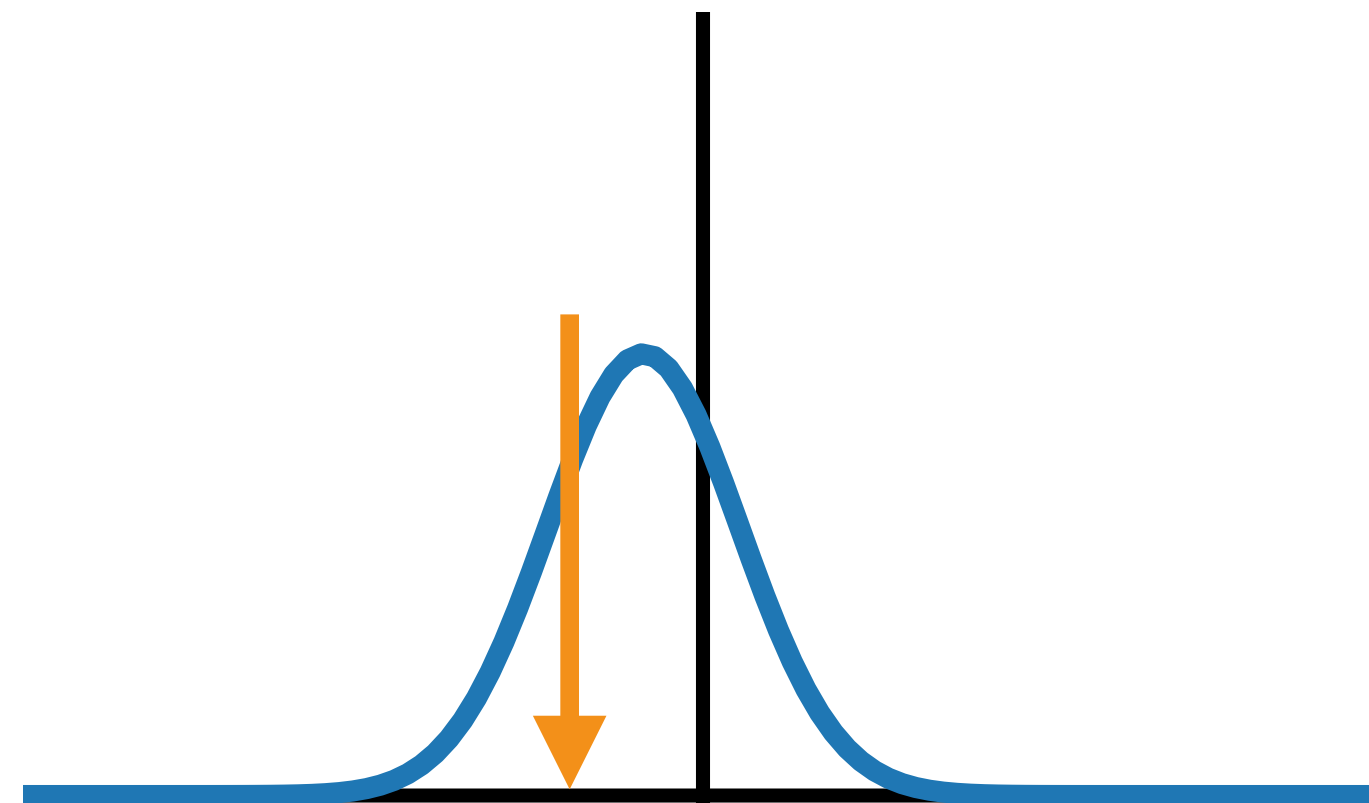
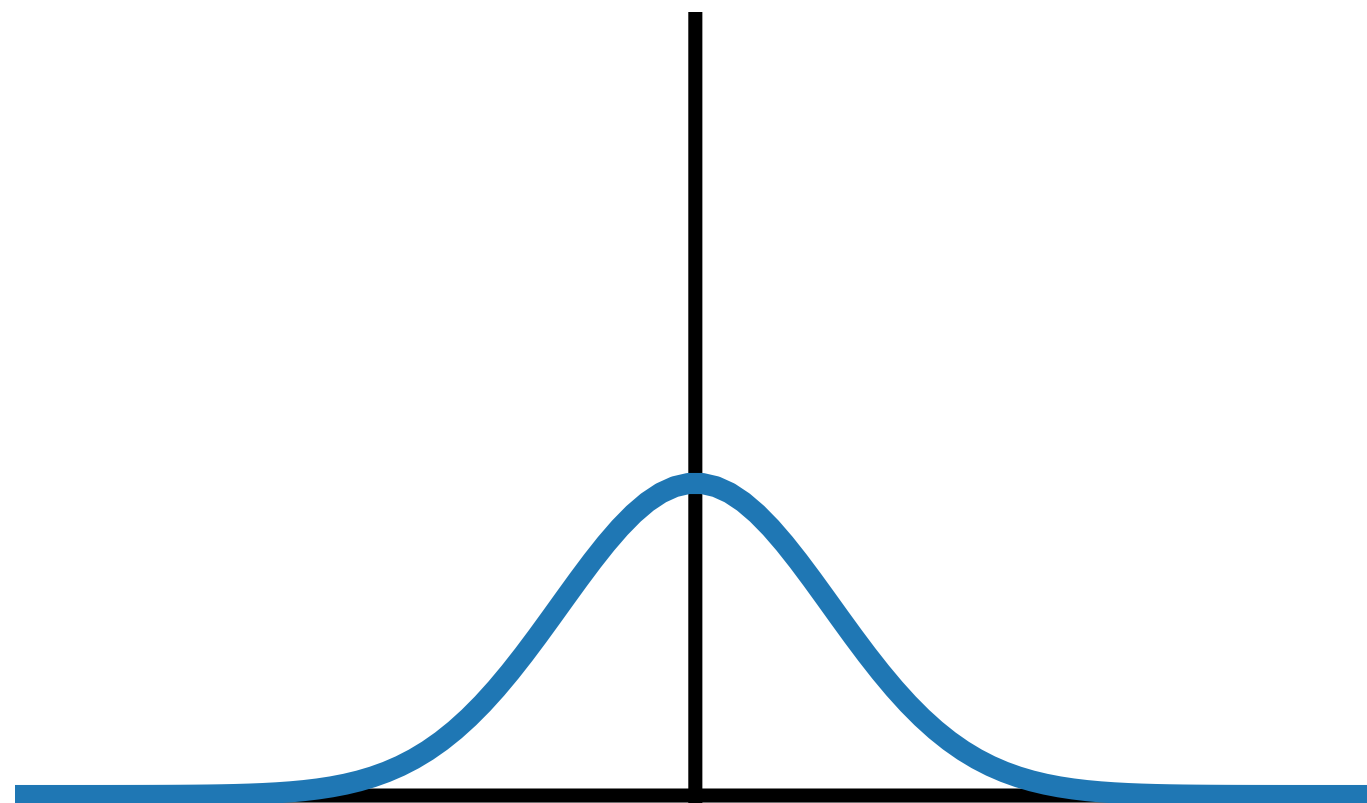
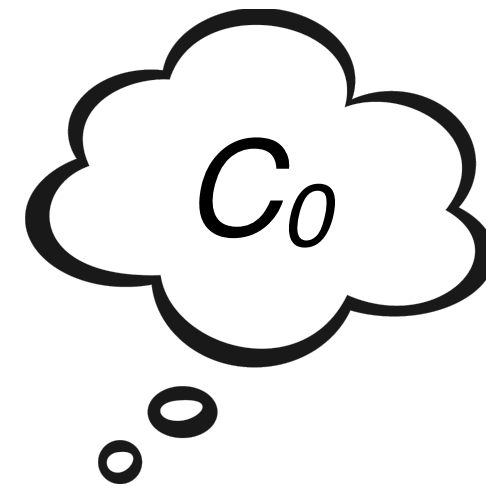

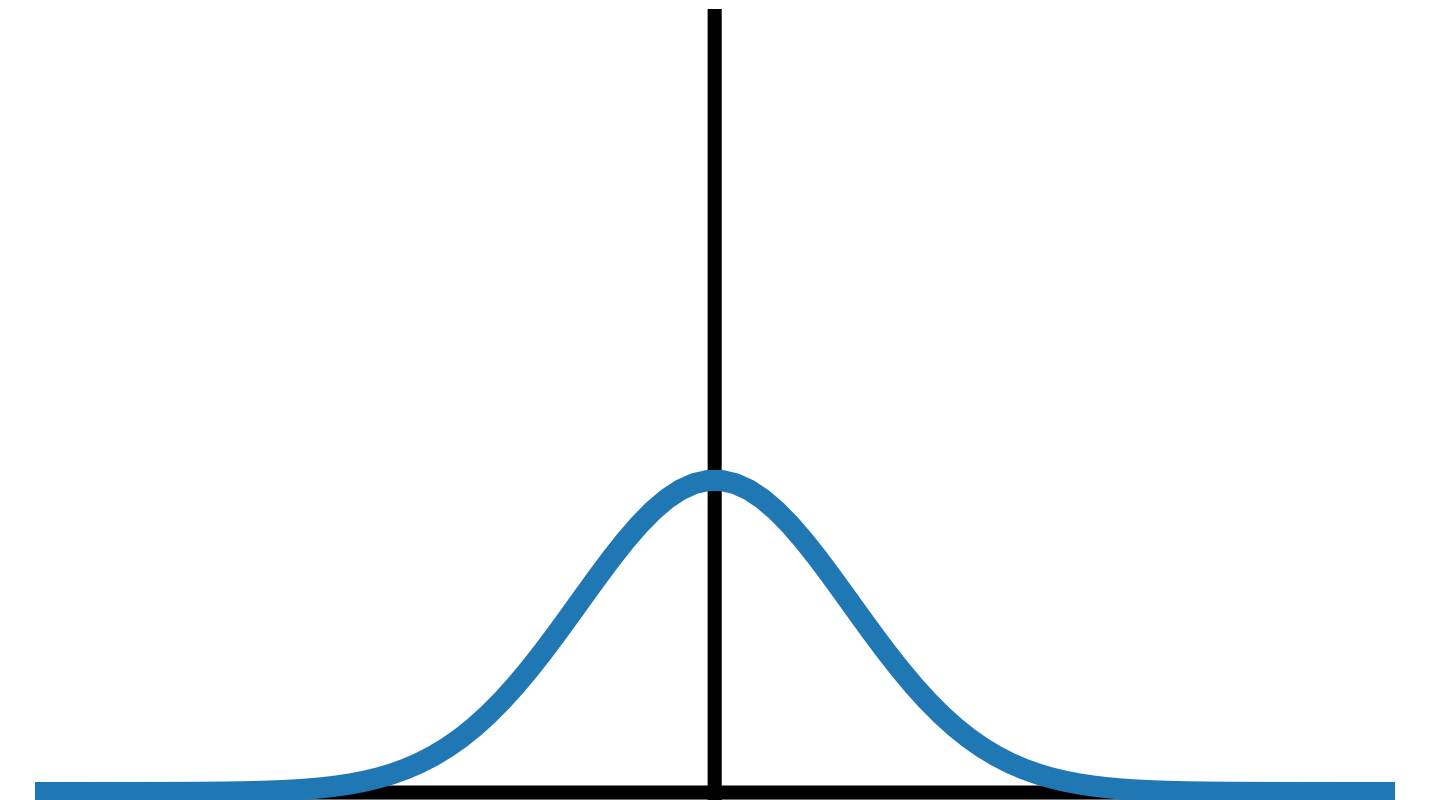
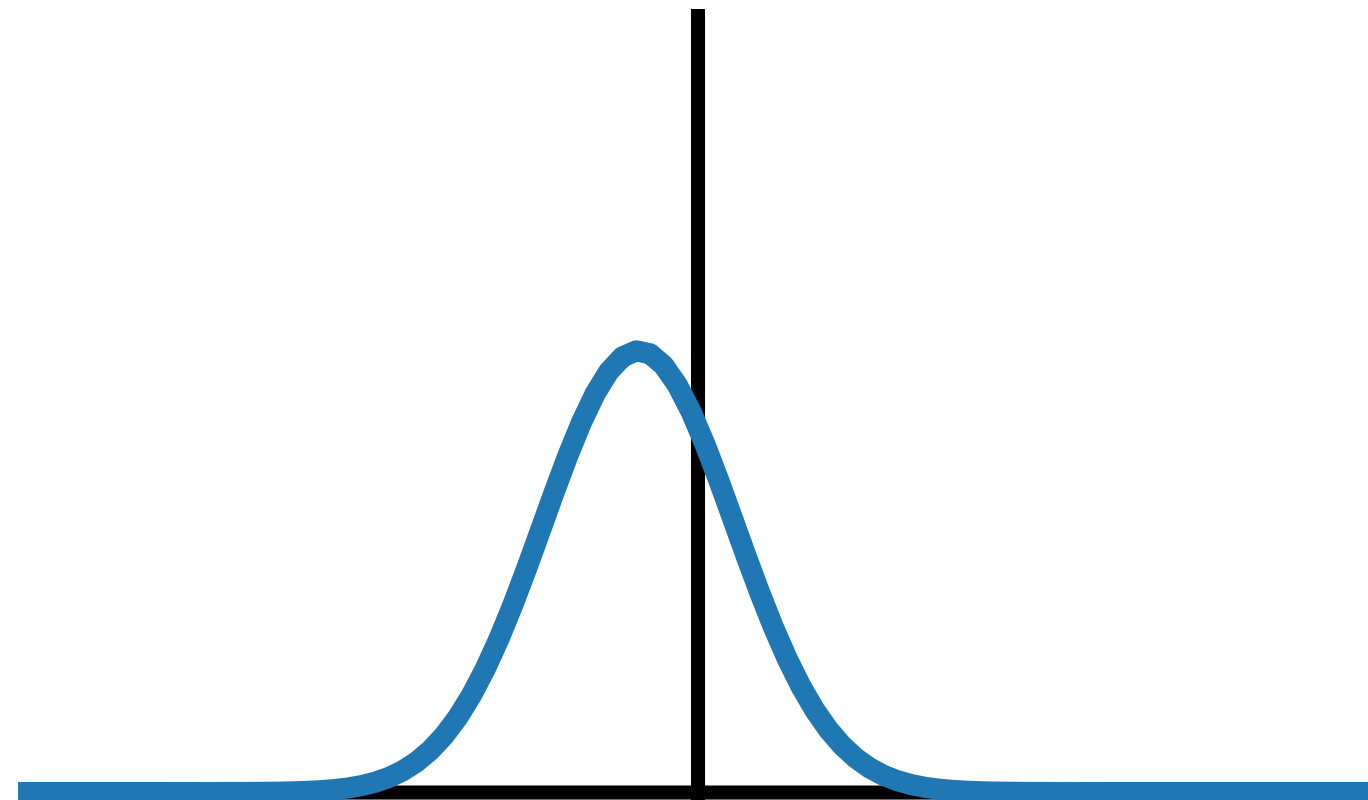
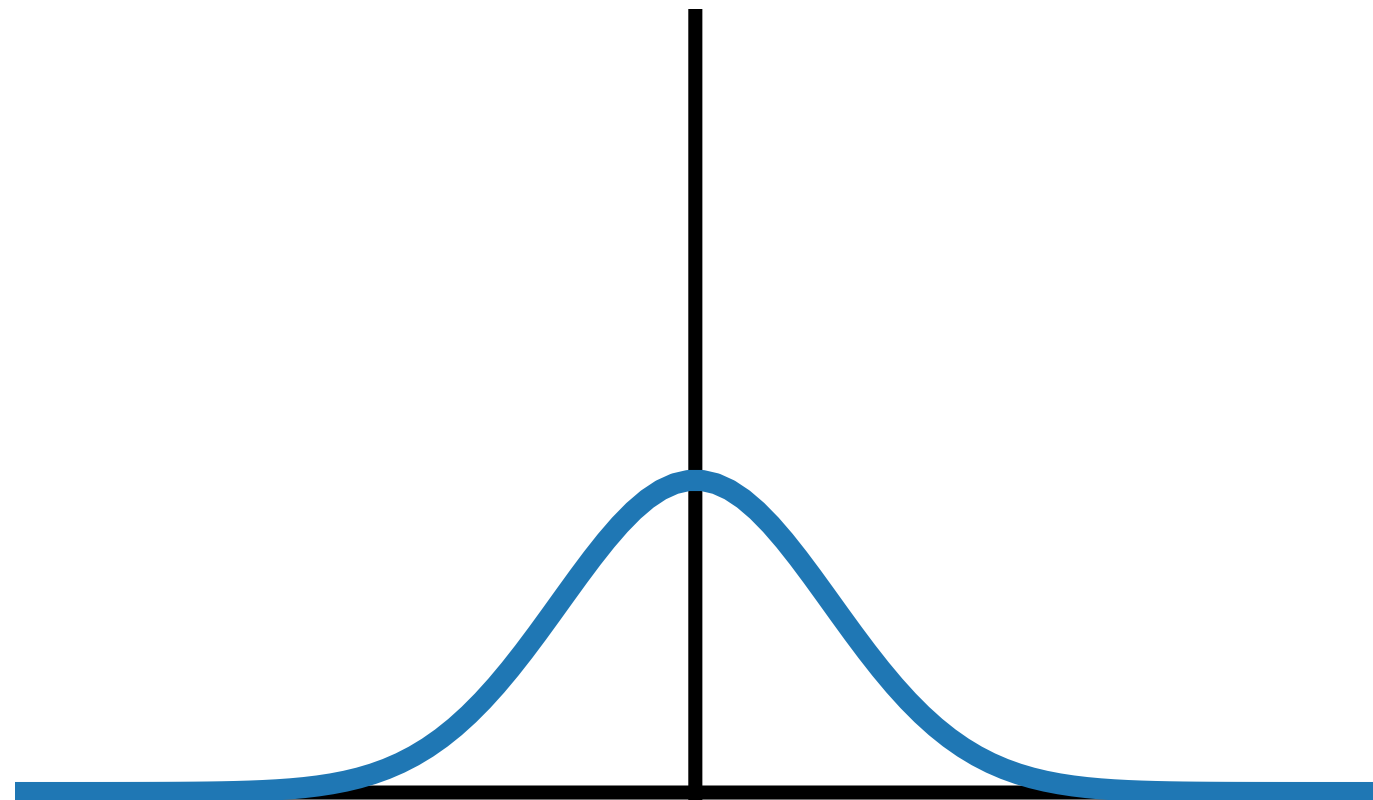

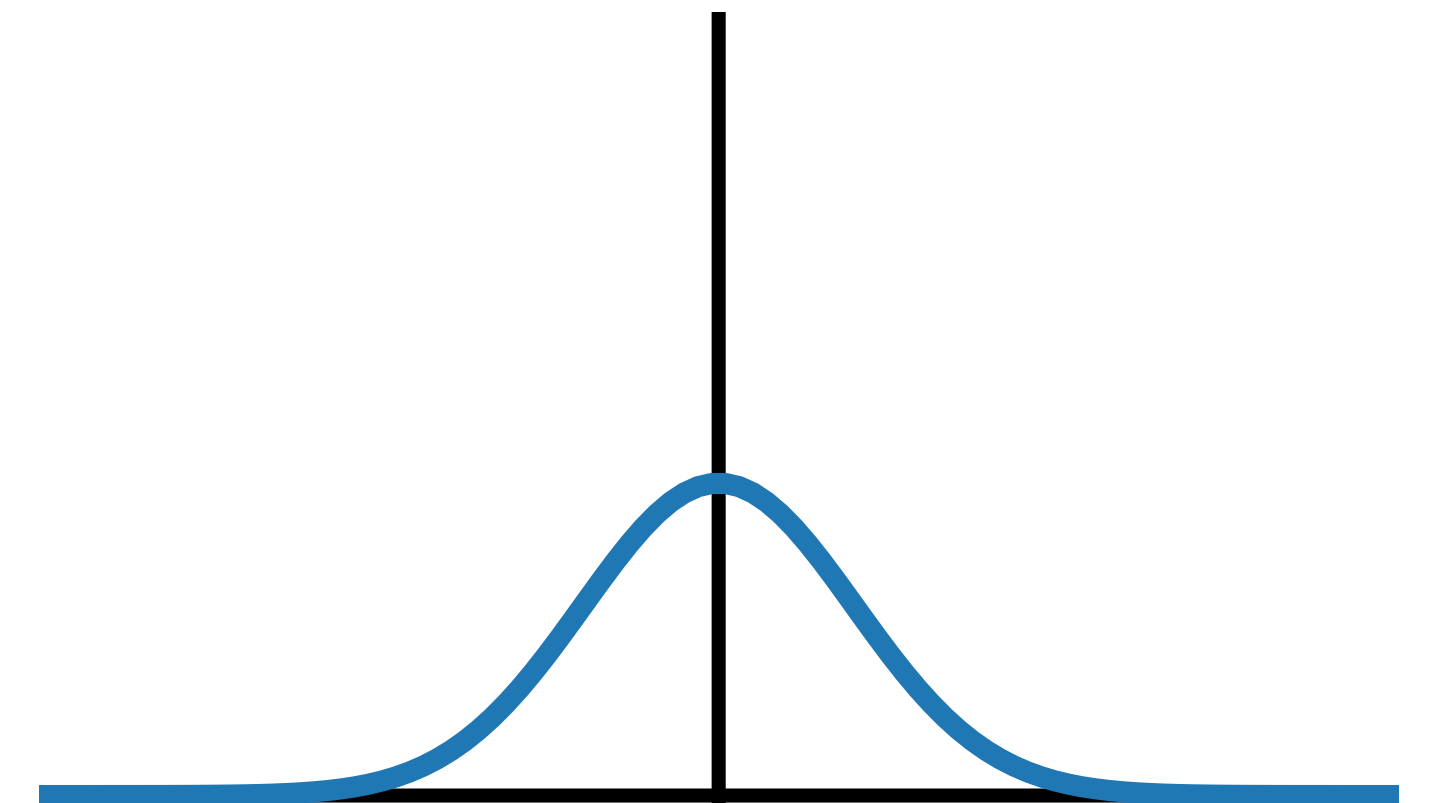
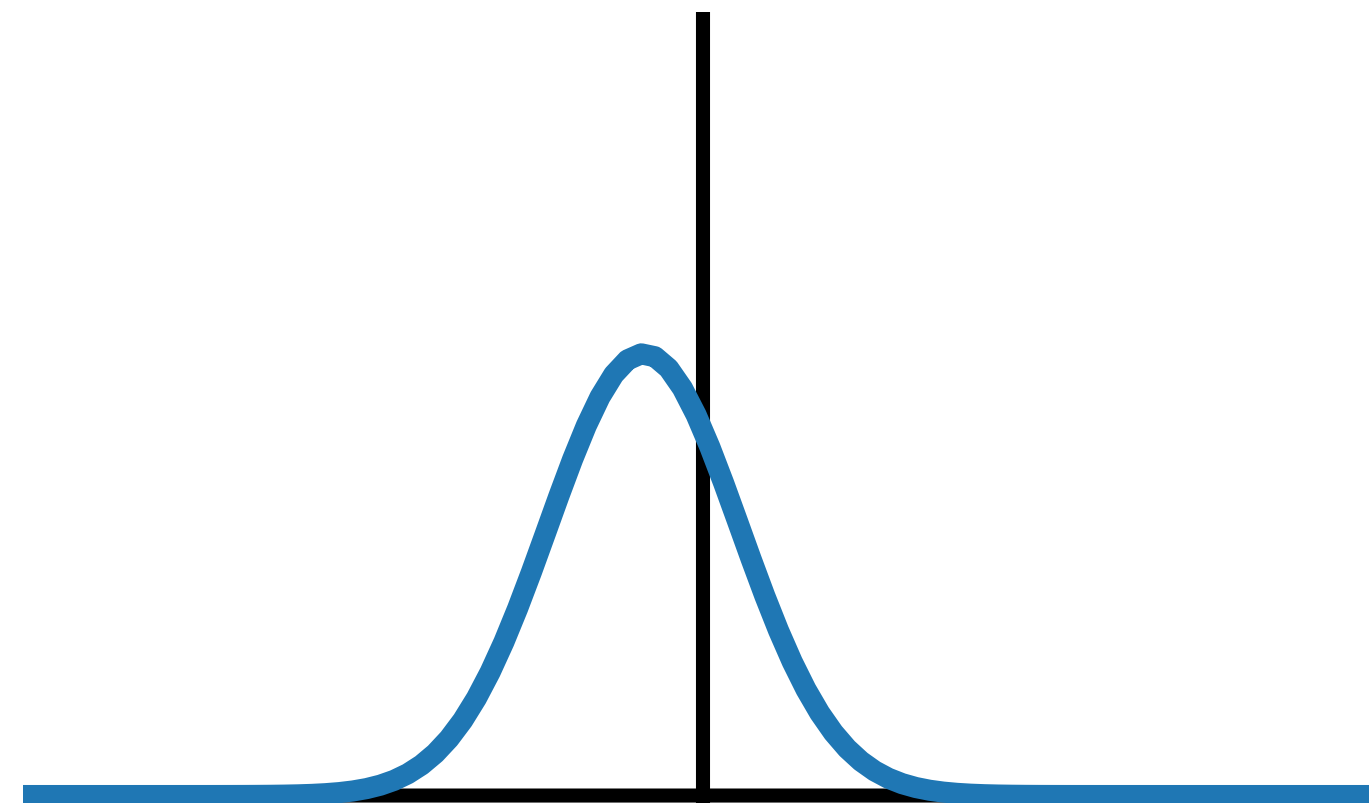
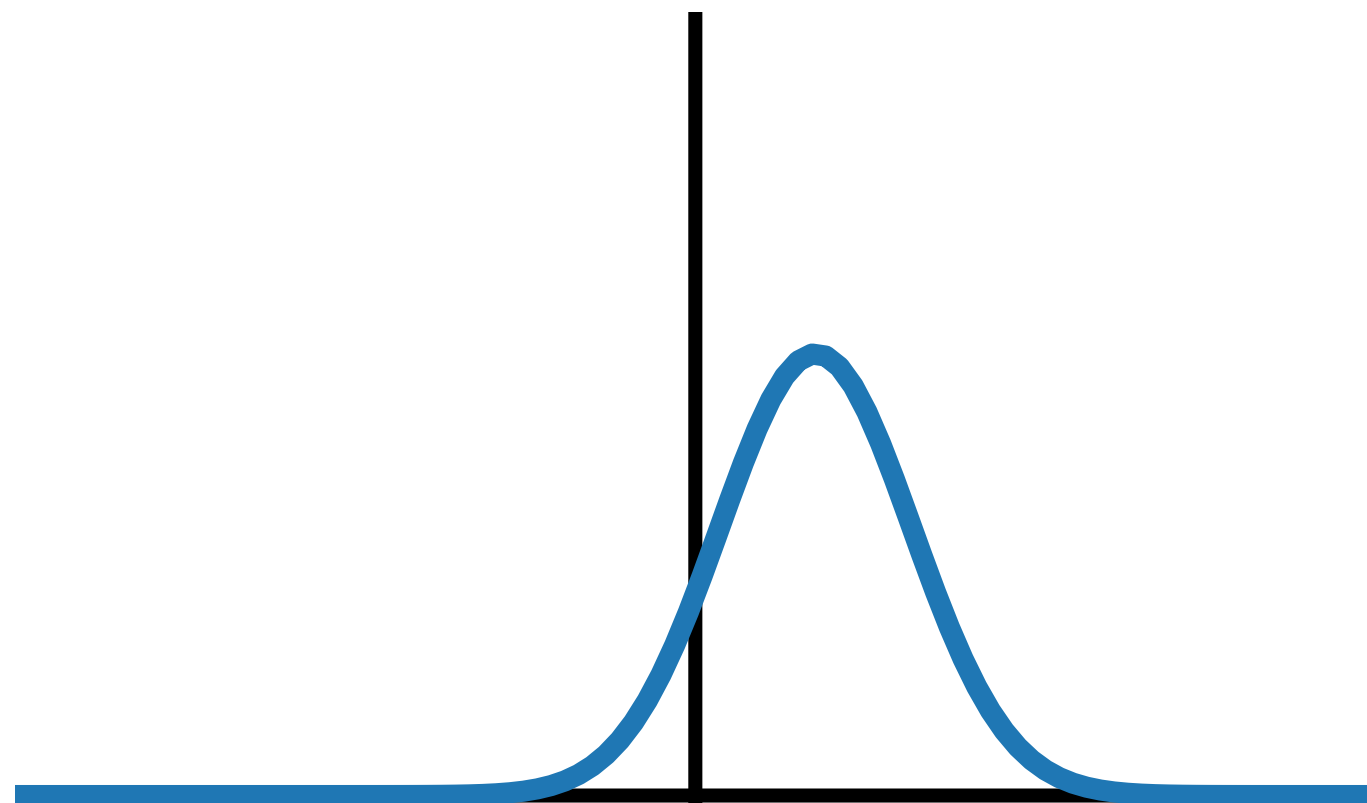

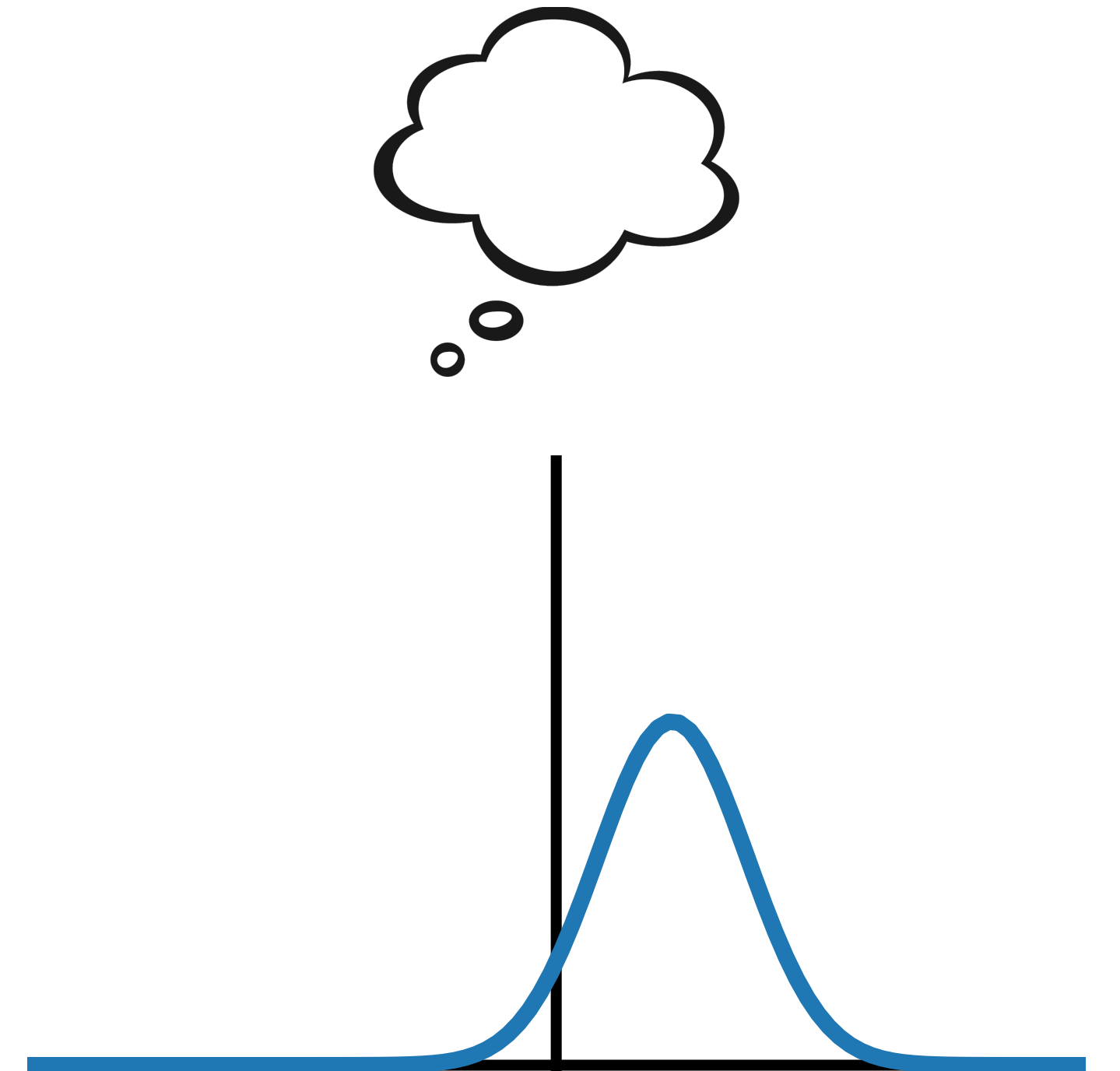
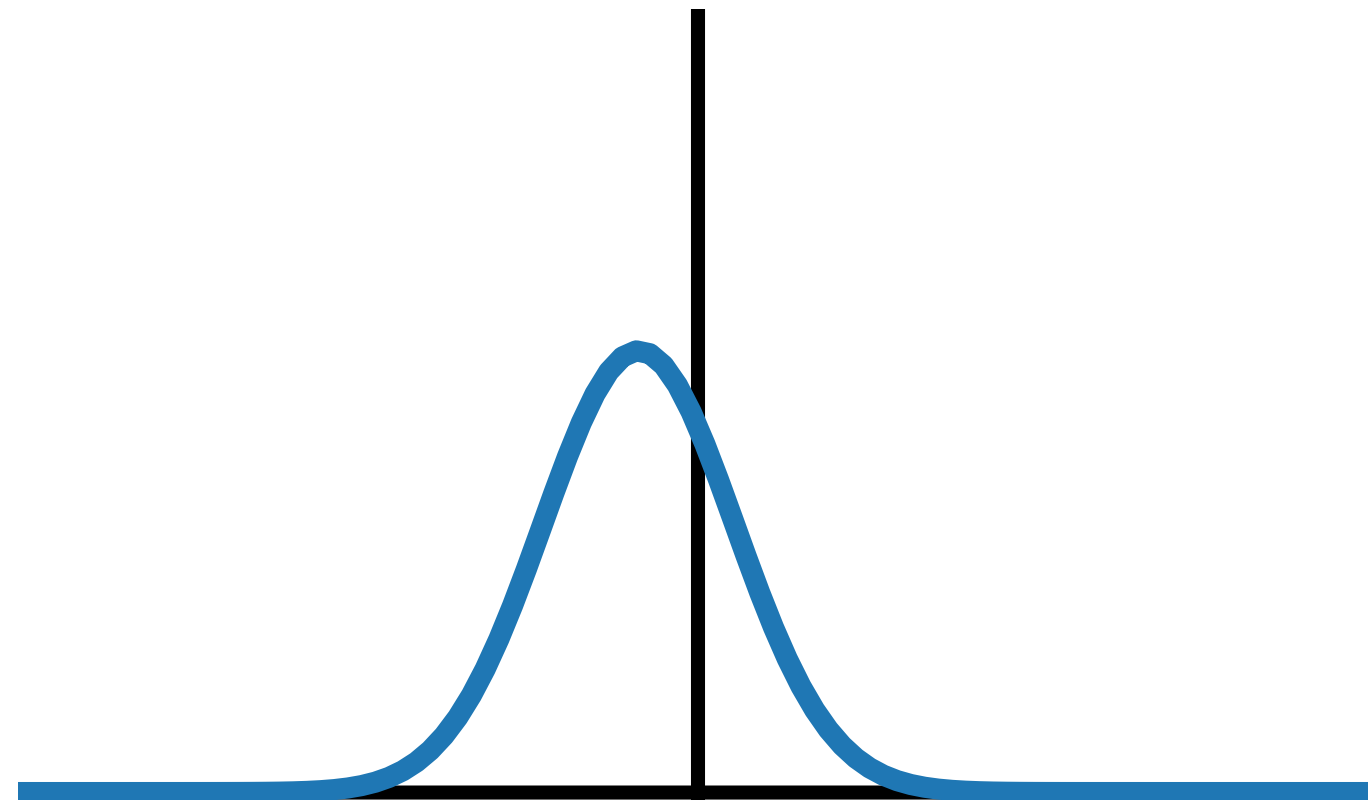
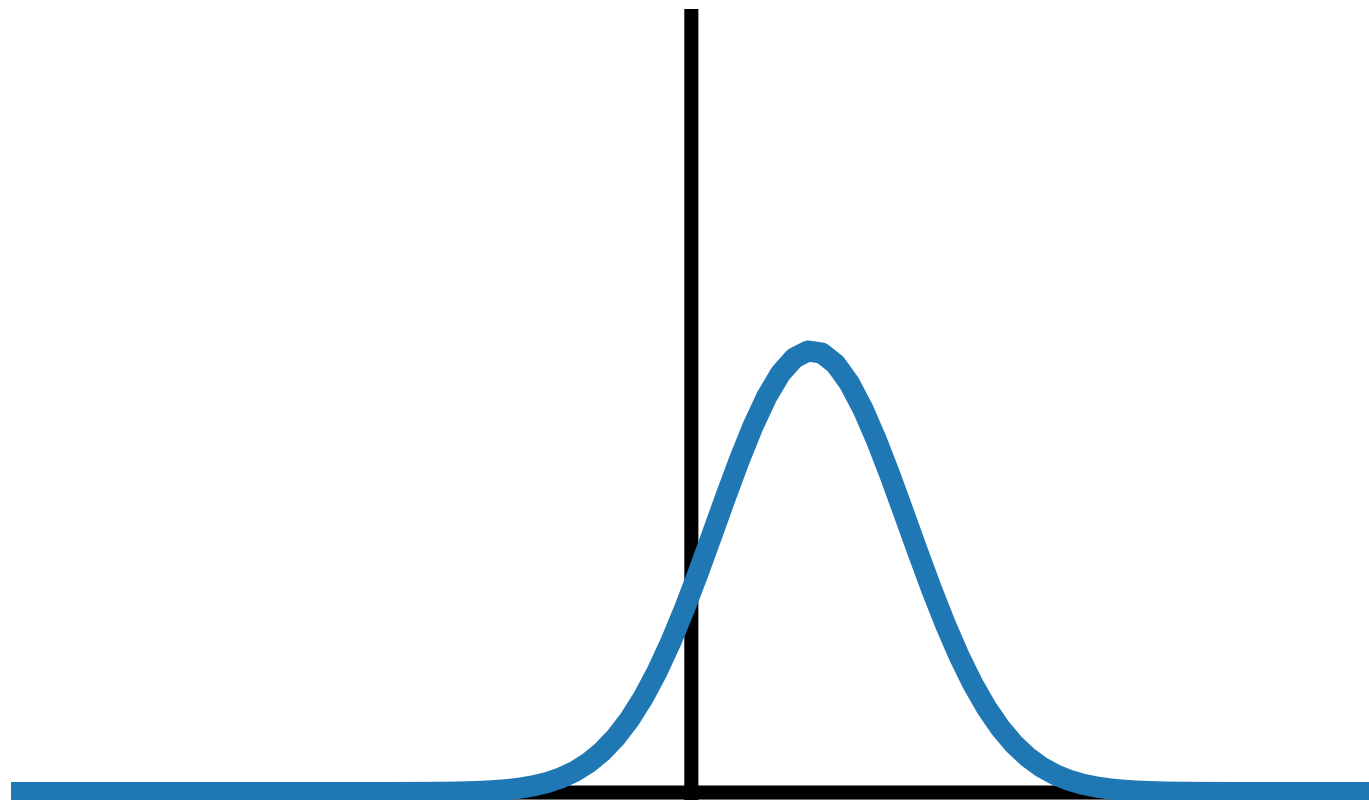

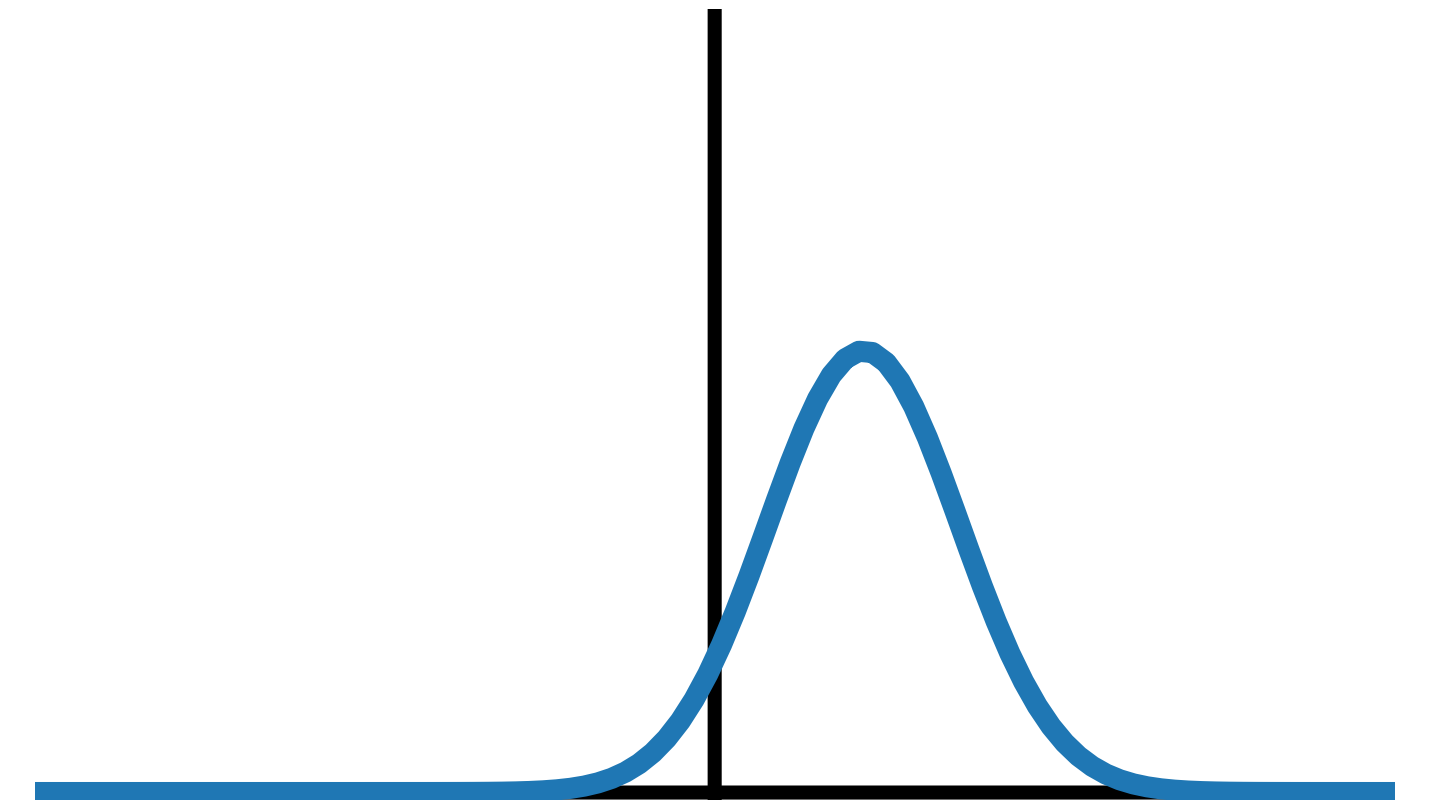
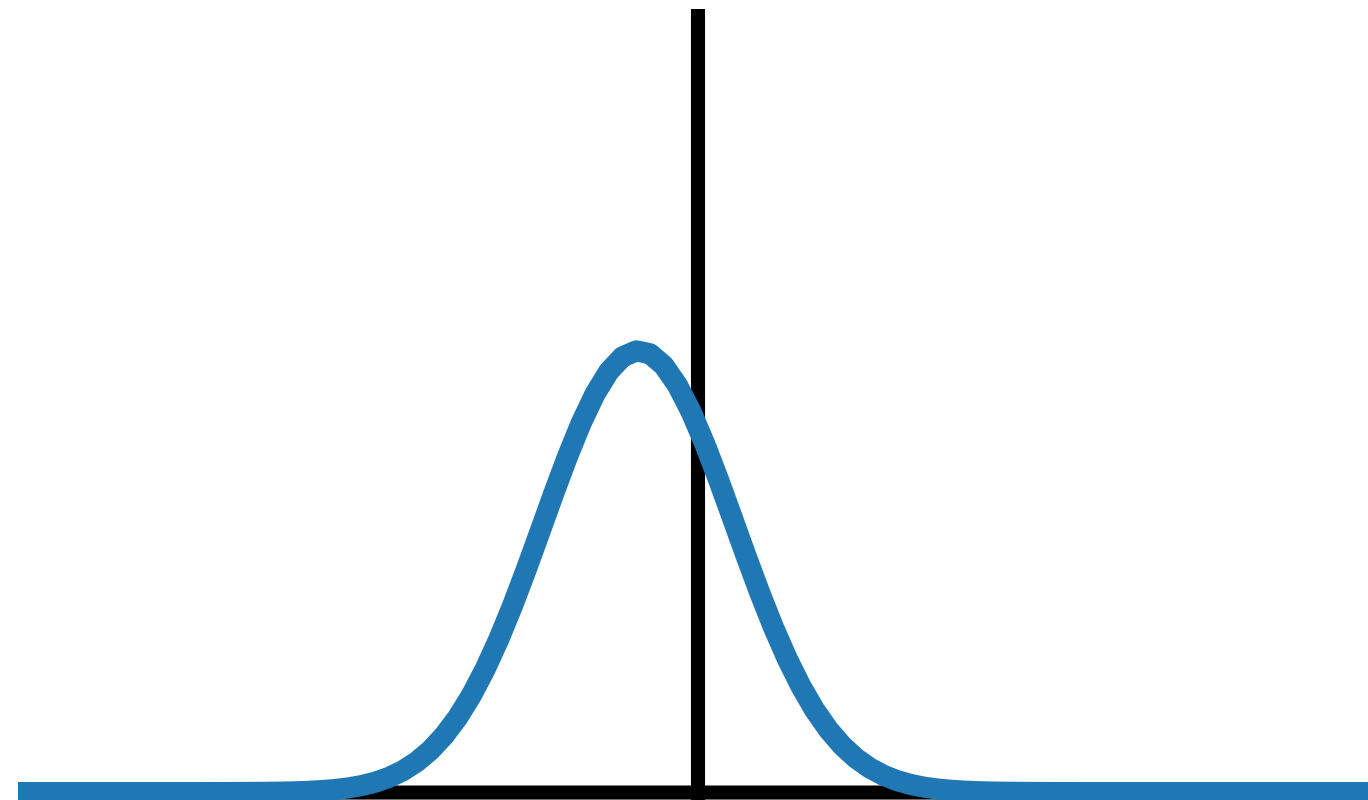
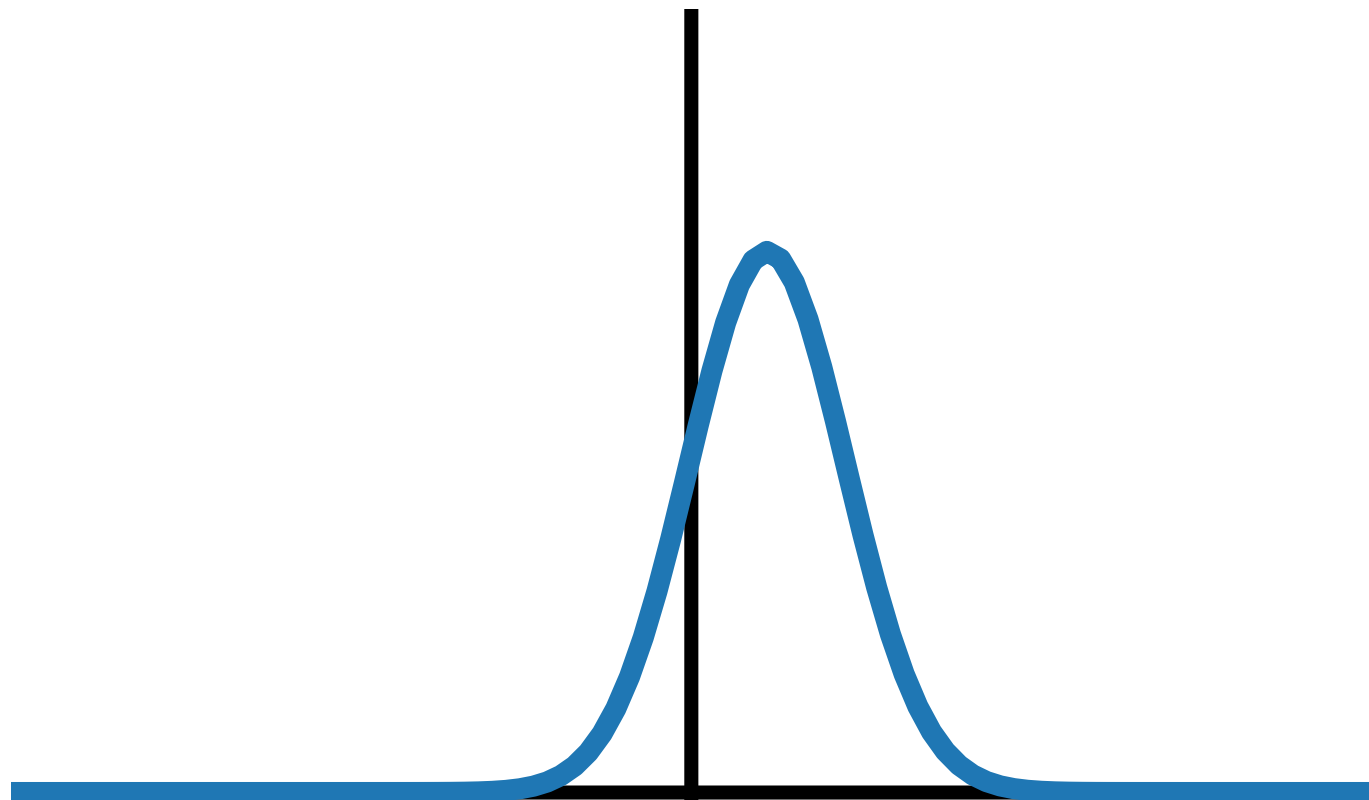



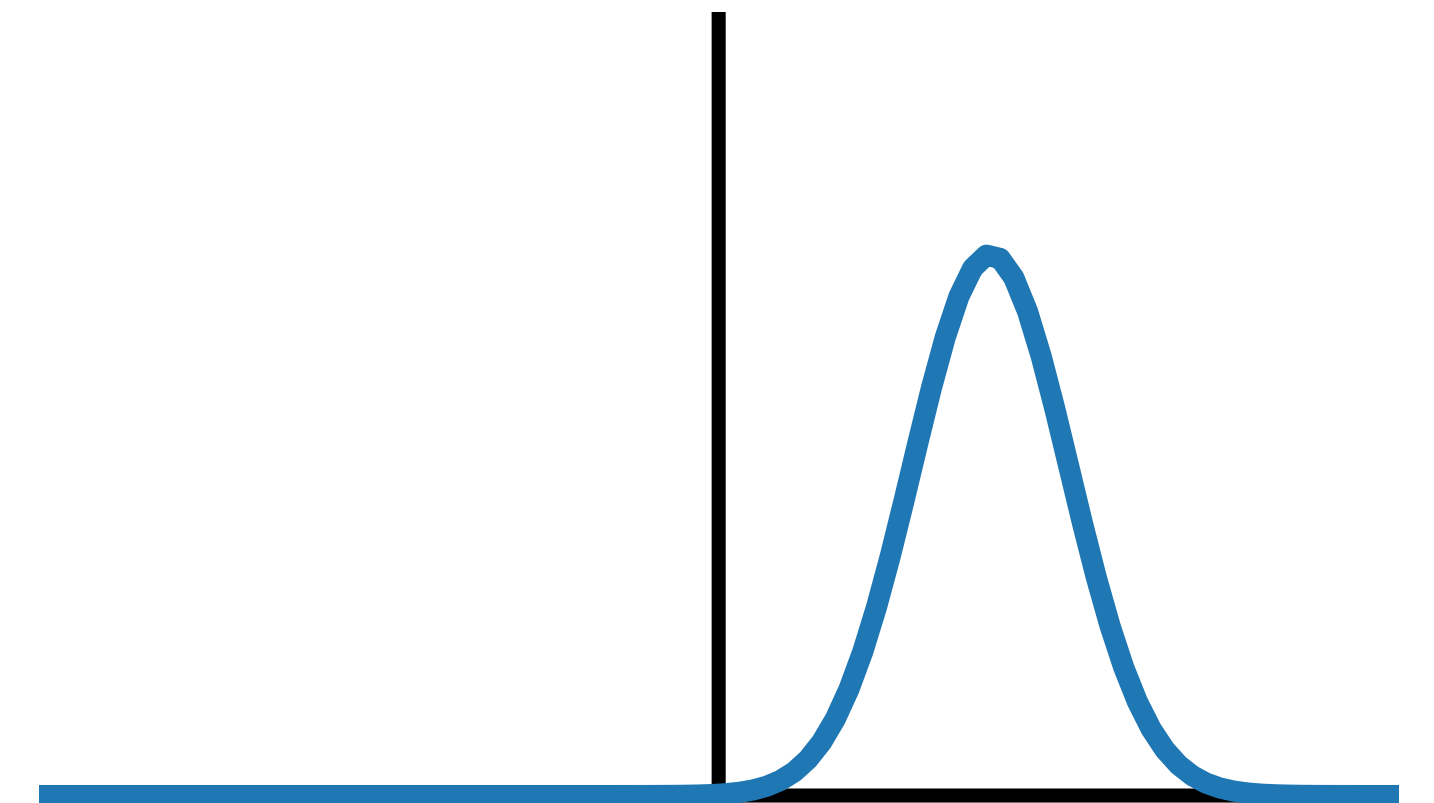
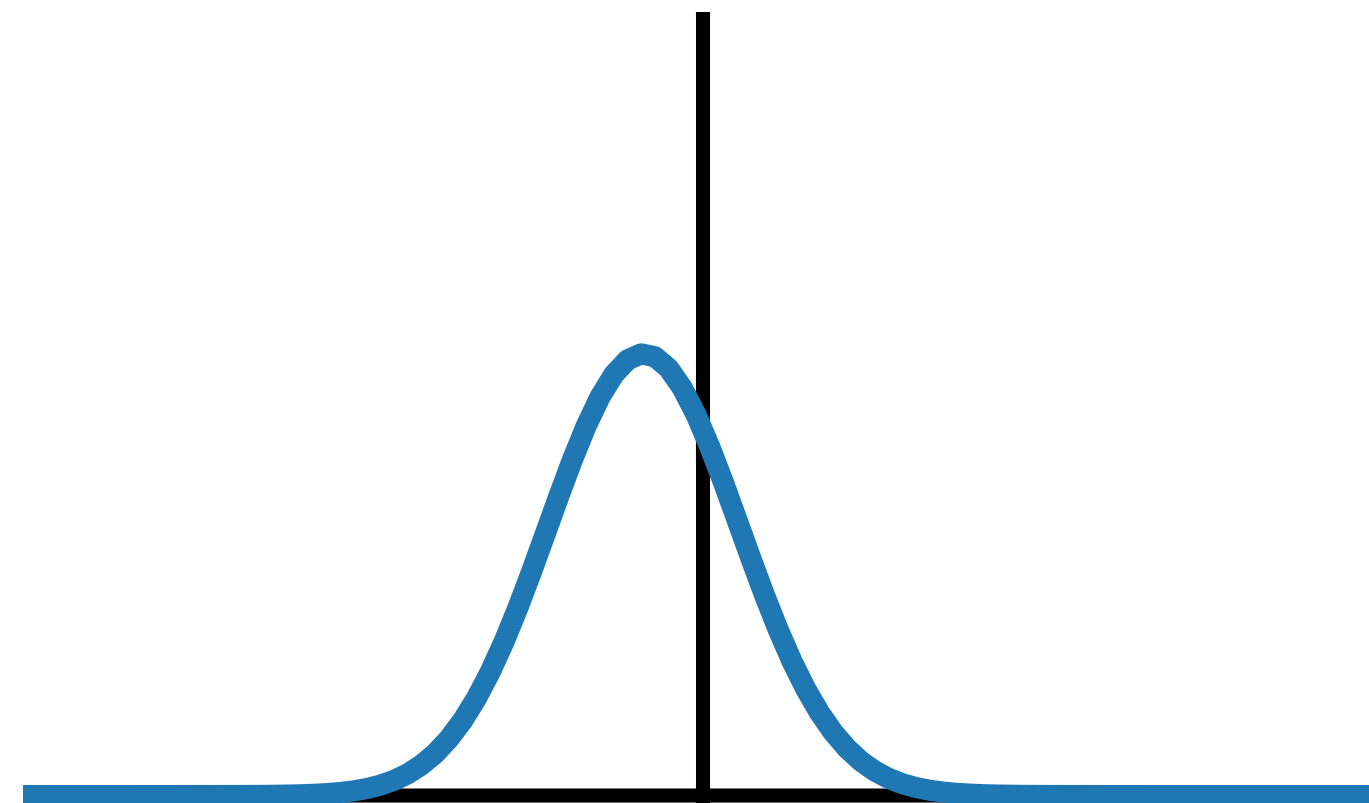
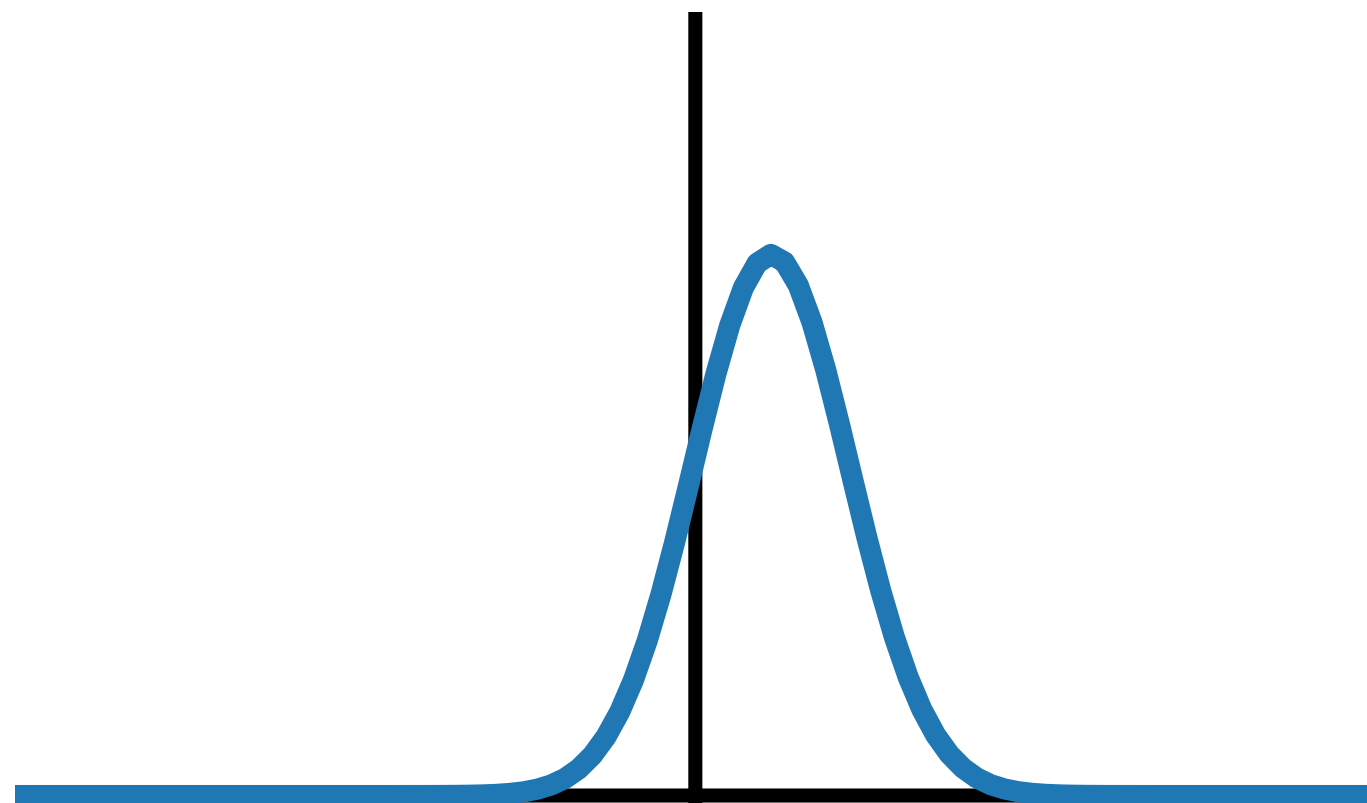

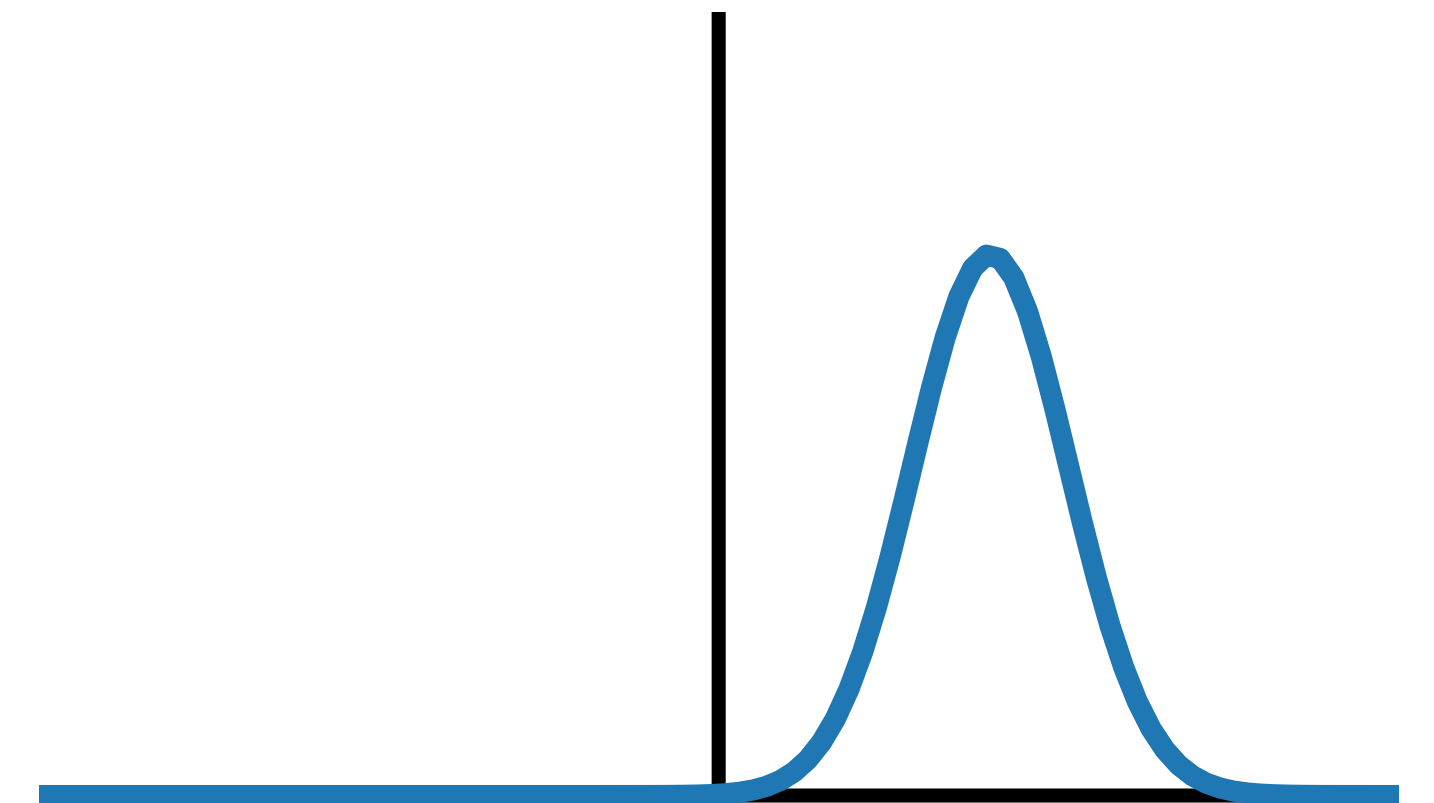
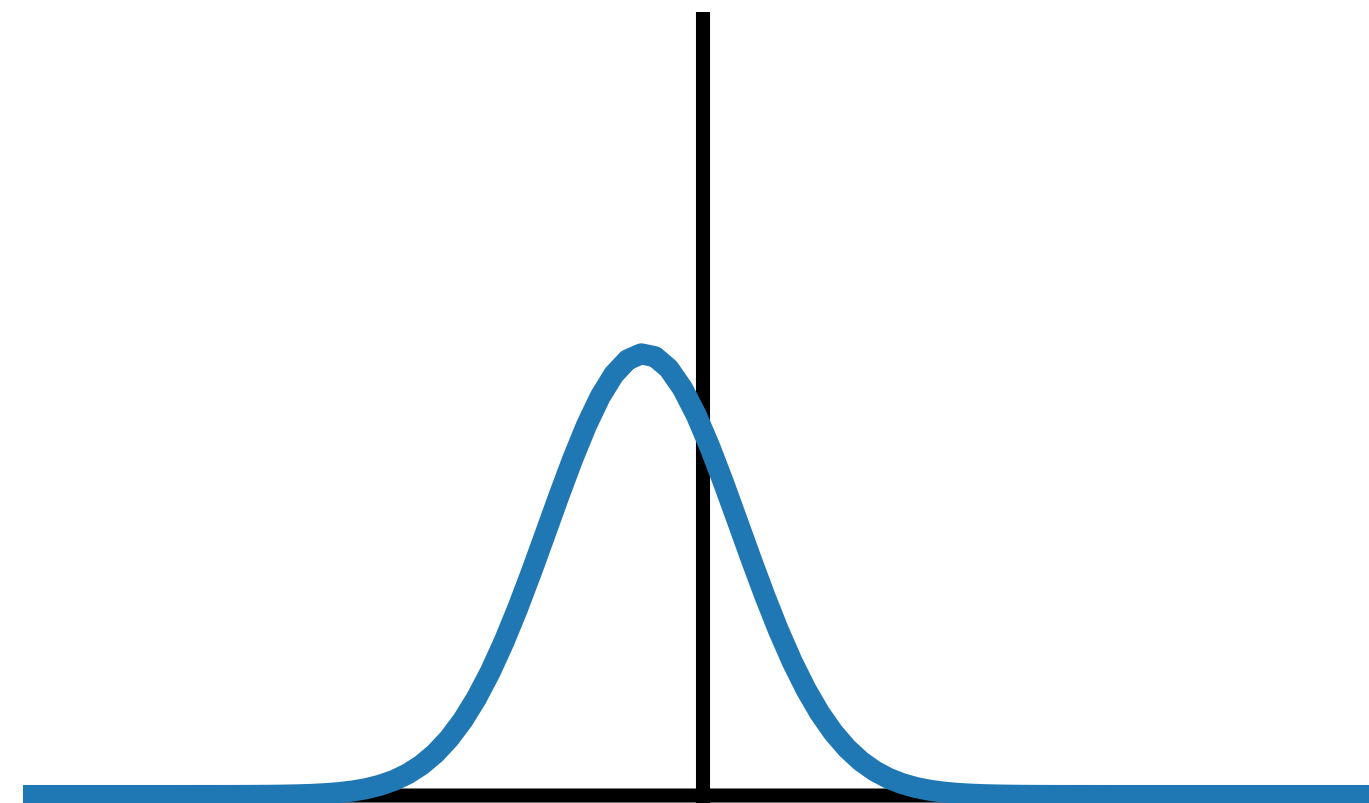
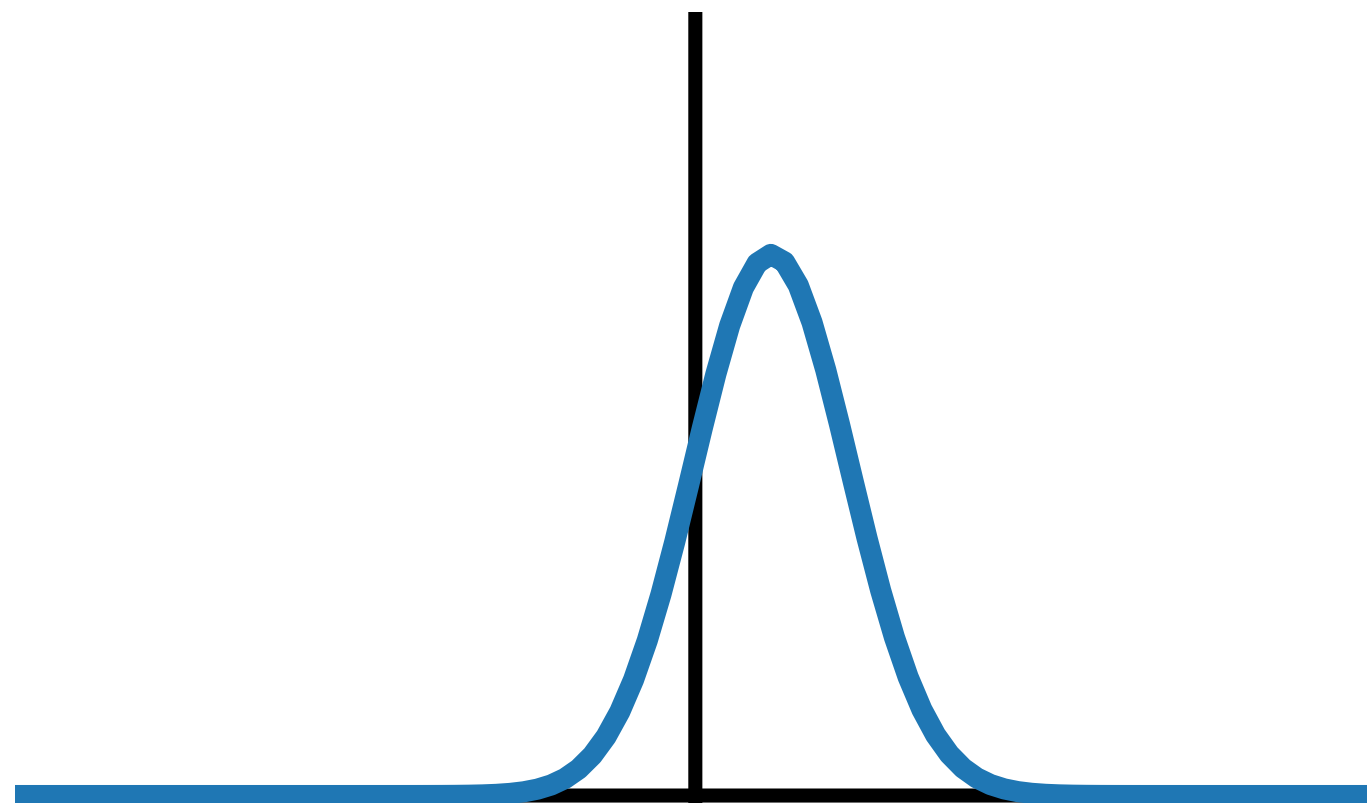
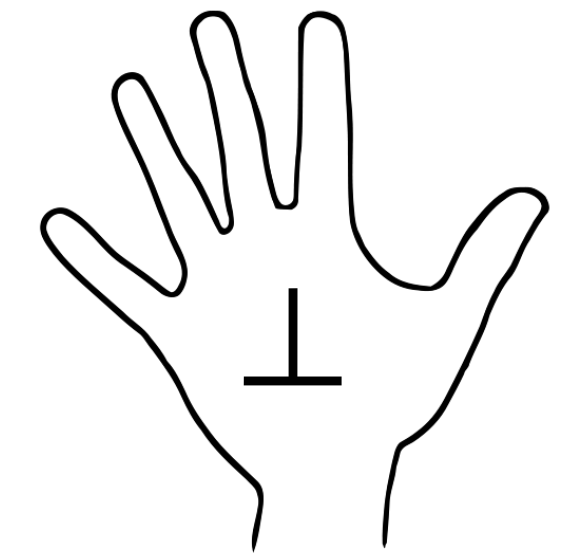

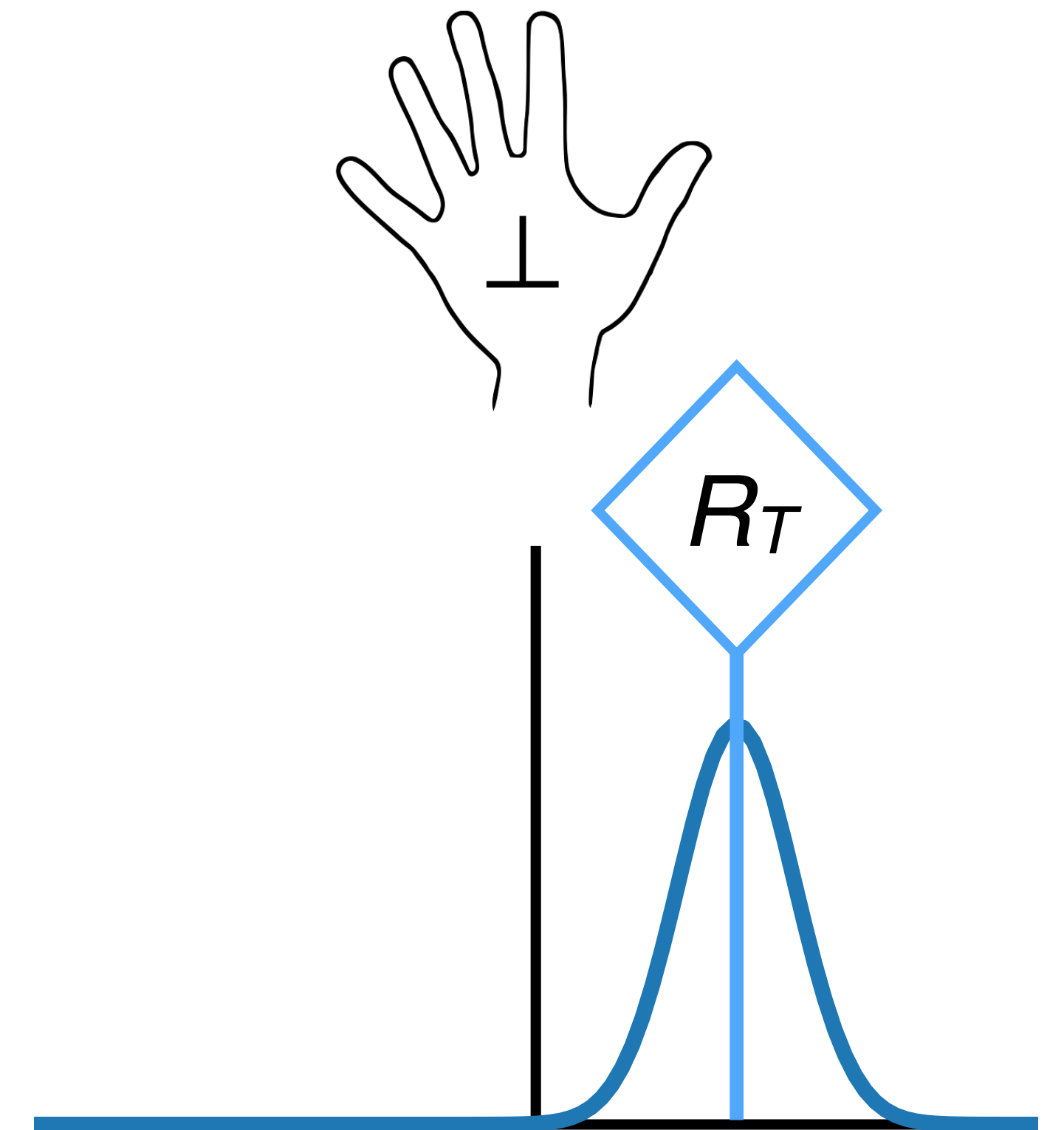
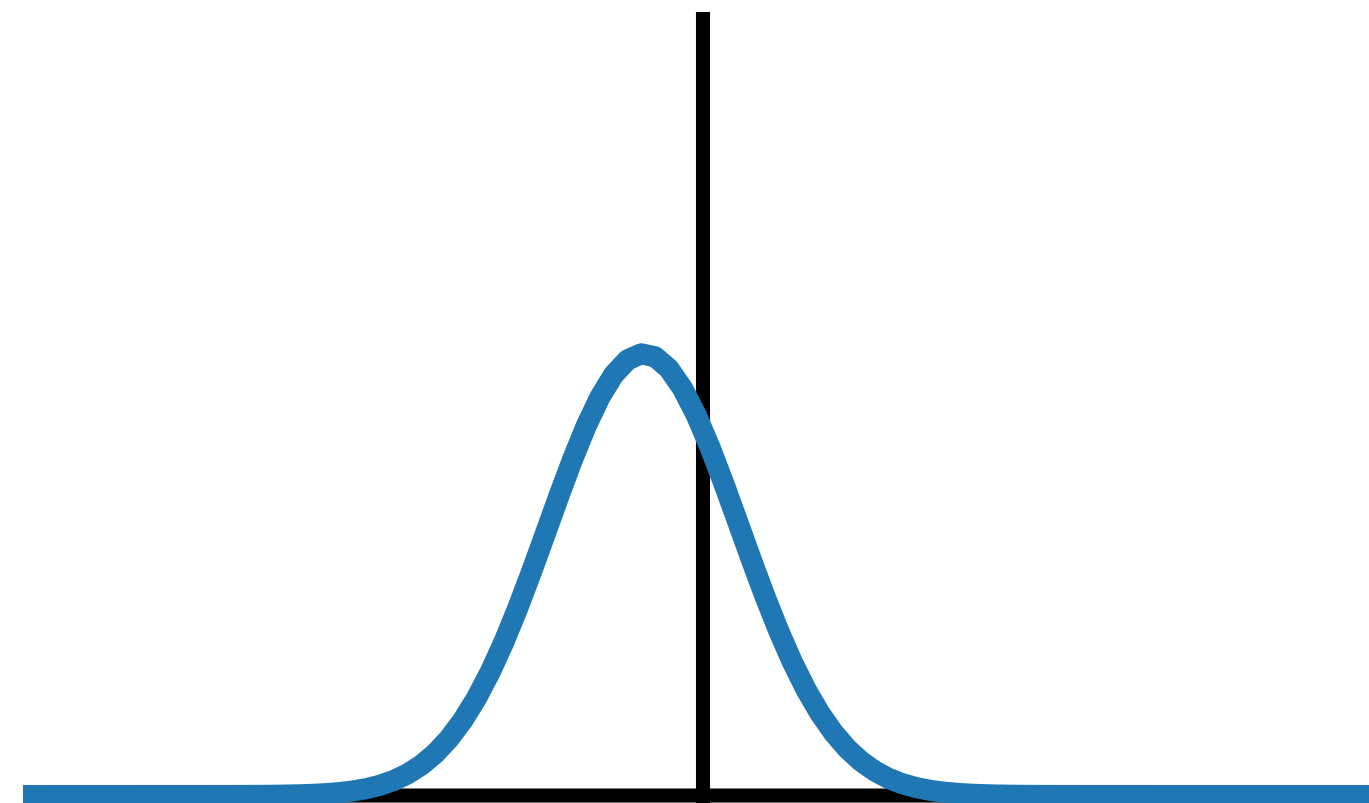
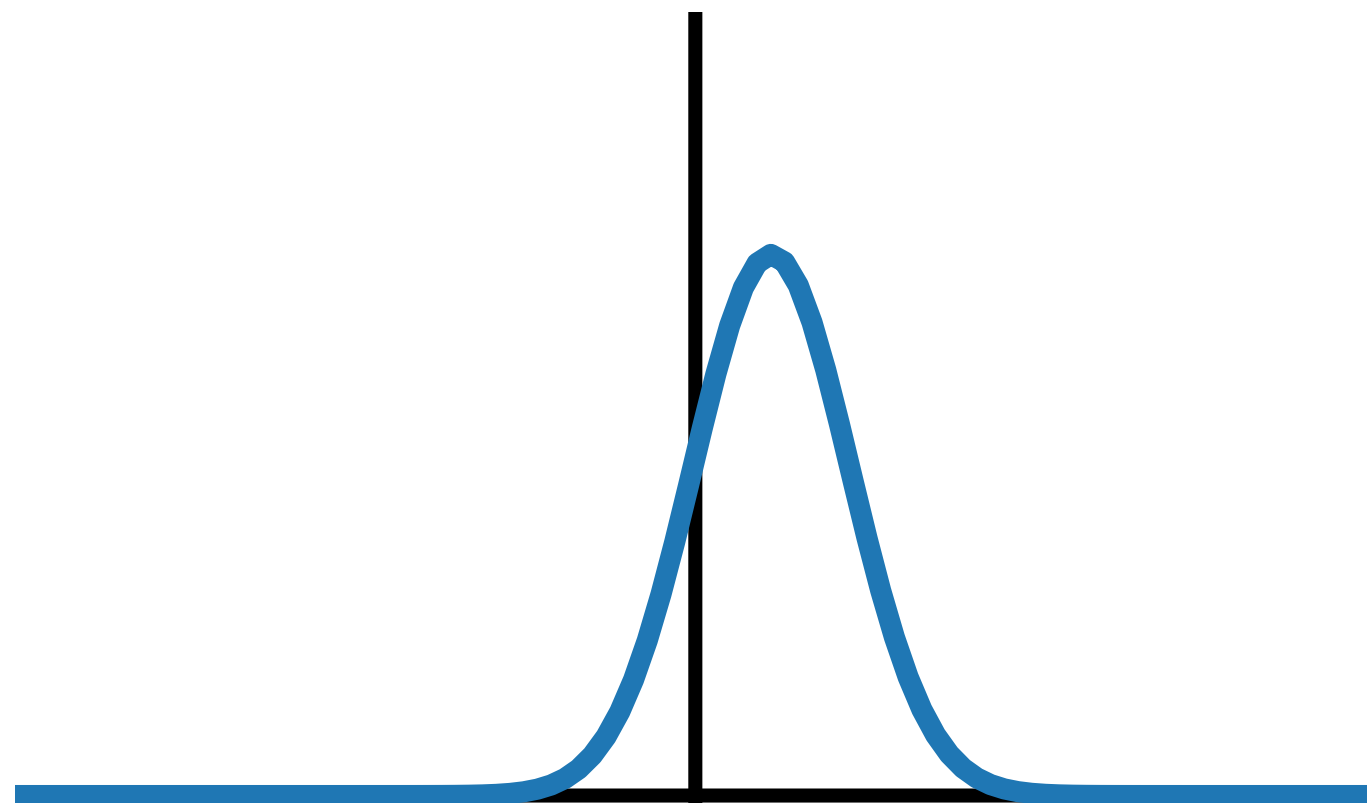

# Results

# Krajbich & Rangel (2011)

- ▶ Ternary choices between snacks.
- ▶ No time constraint.
- ▶ Eye tracking.
- ▶ Each item rated beforehand.

A

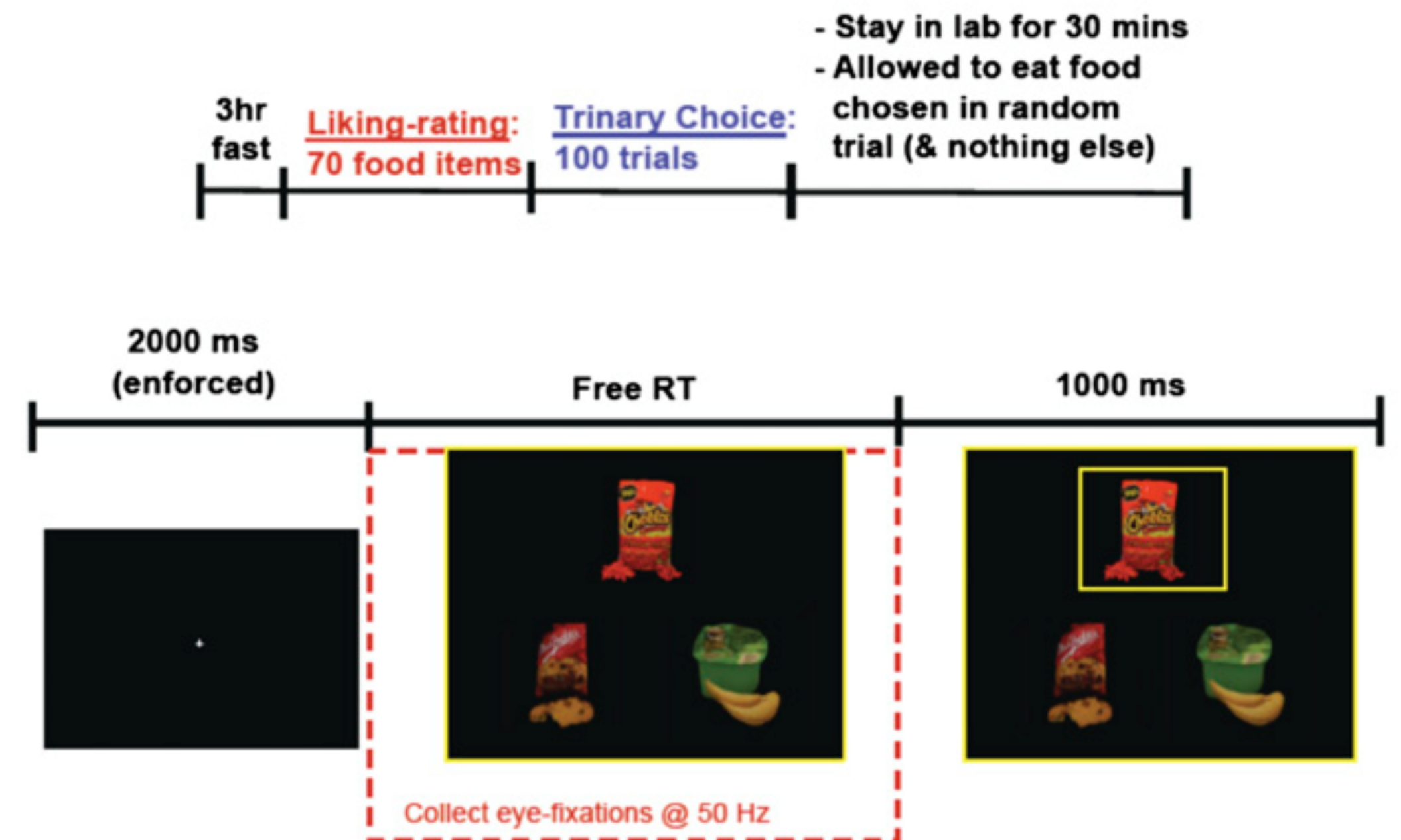

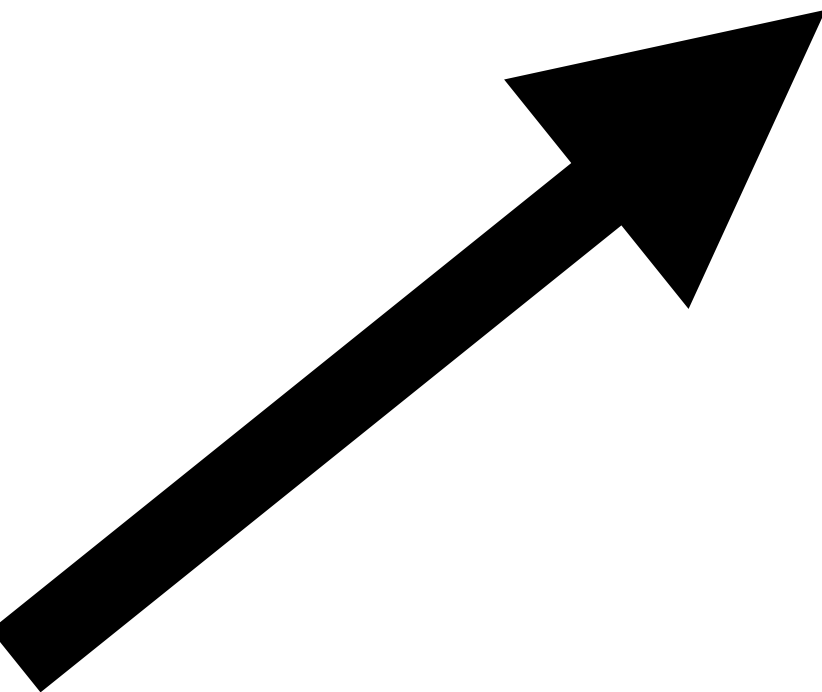
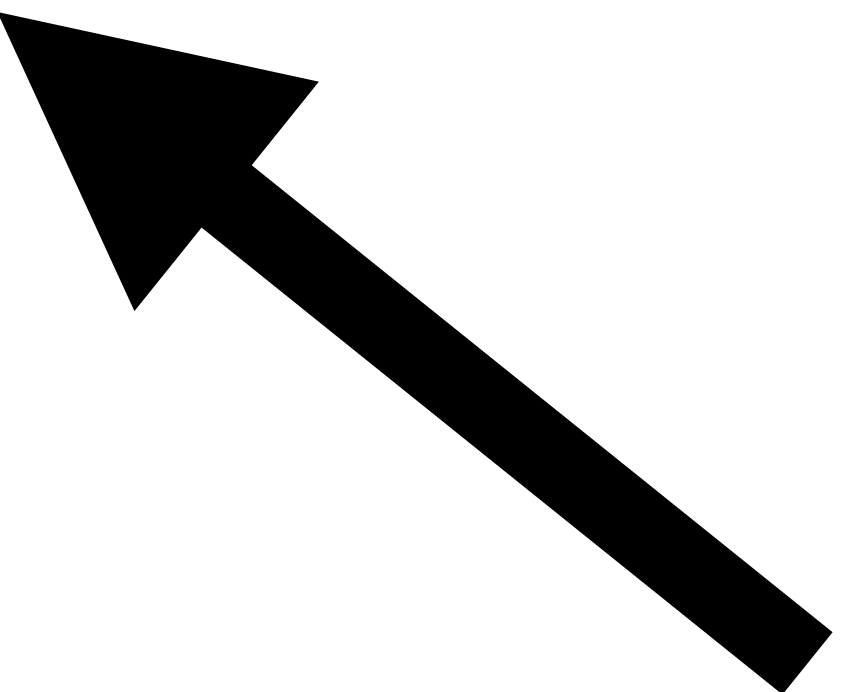
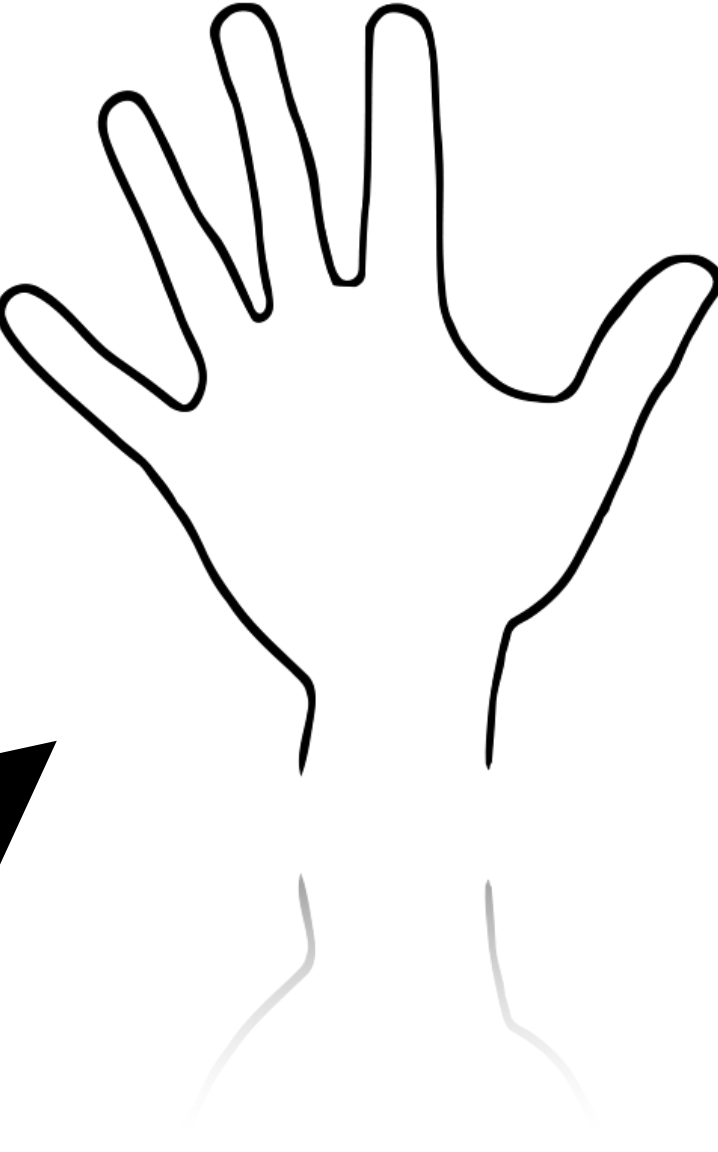
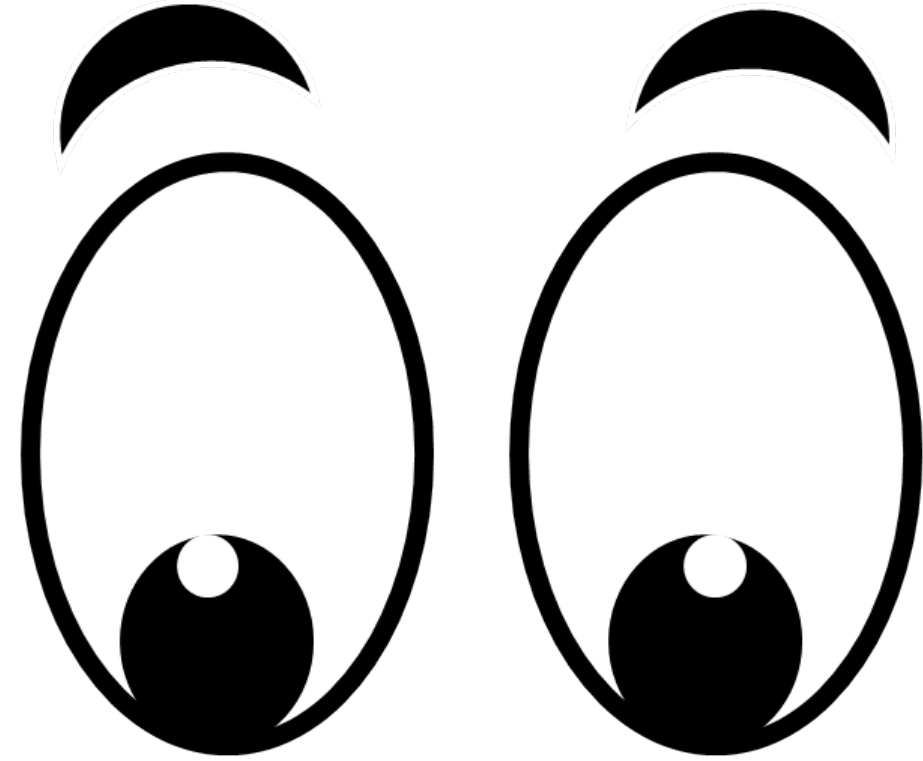

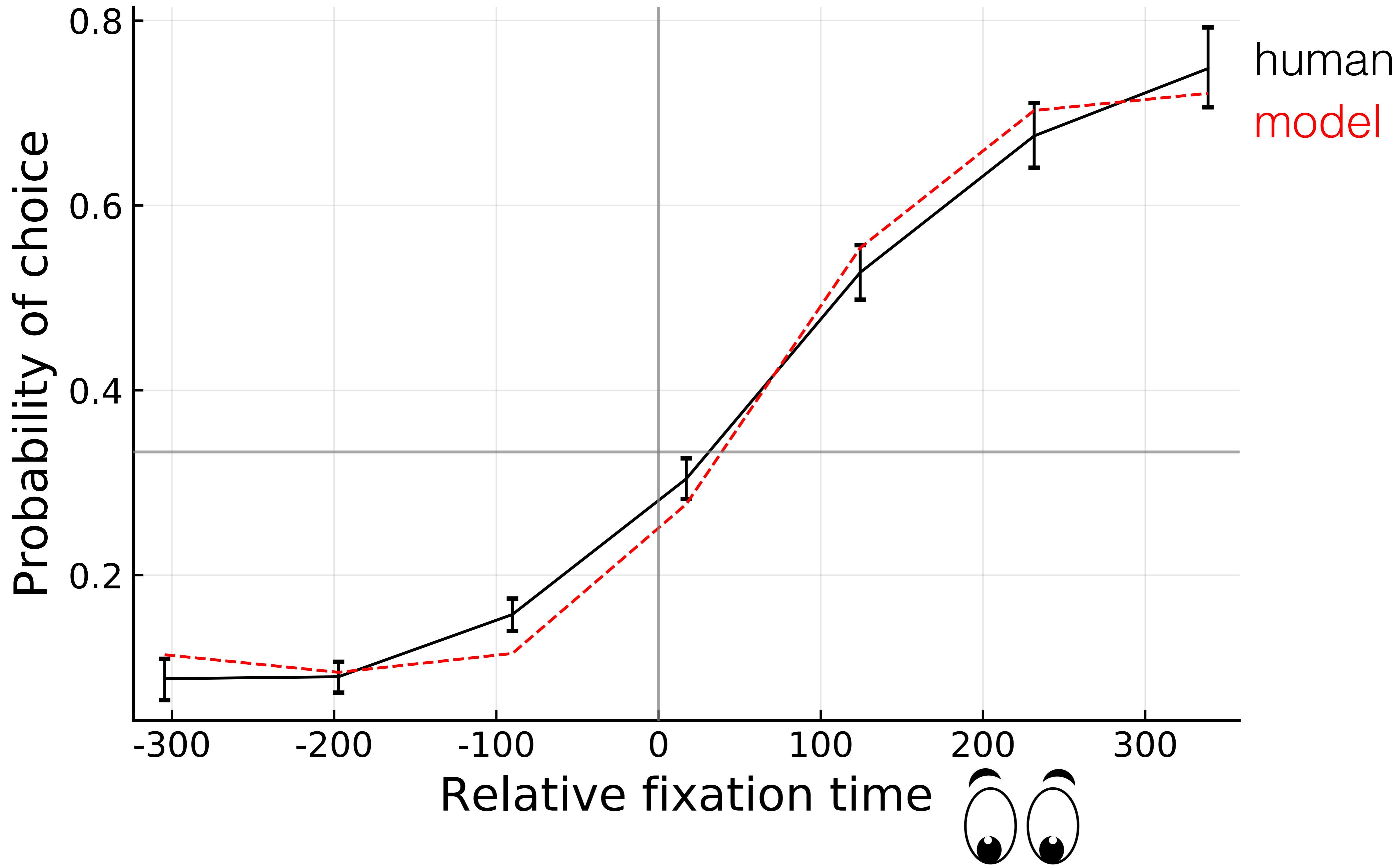

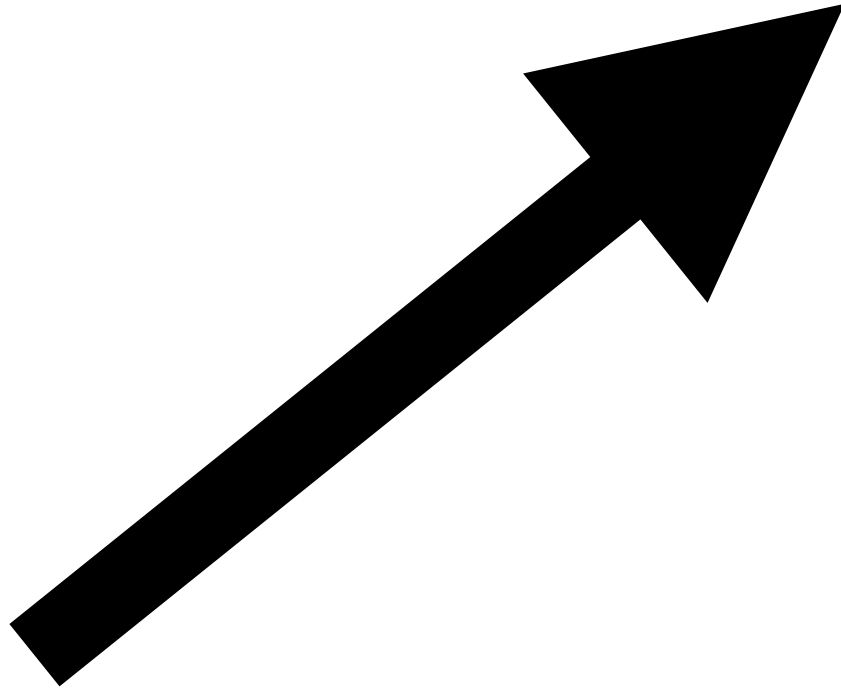
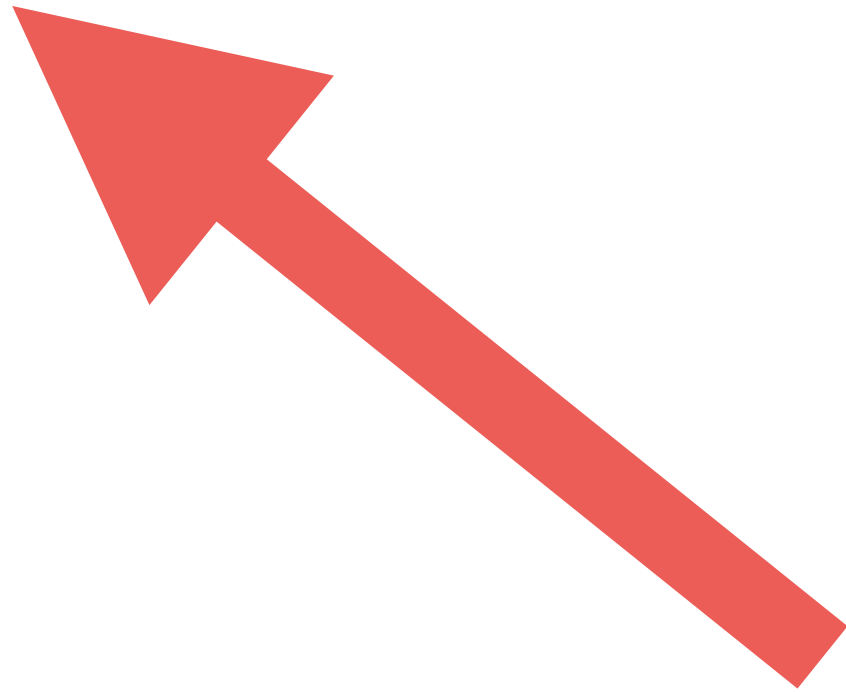
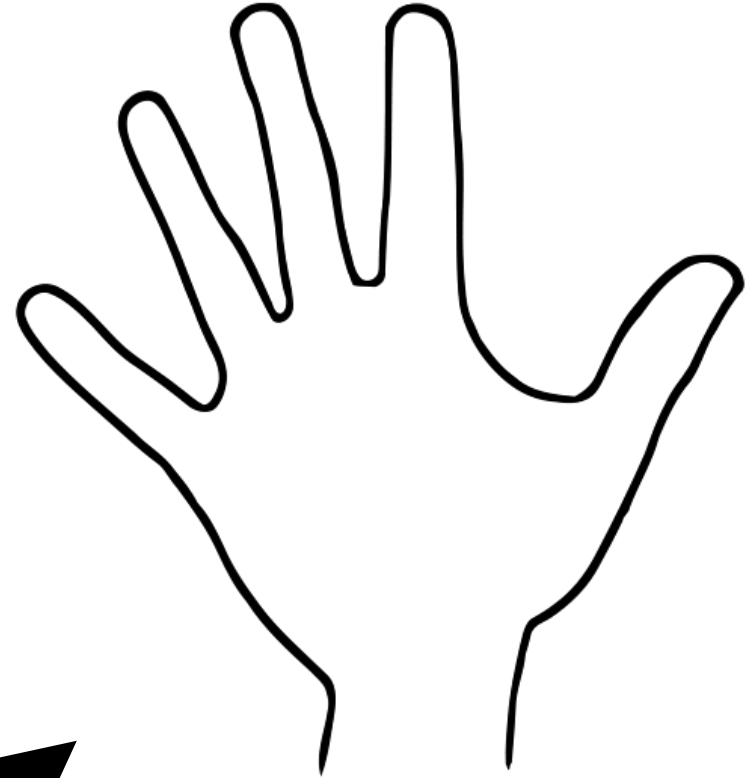
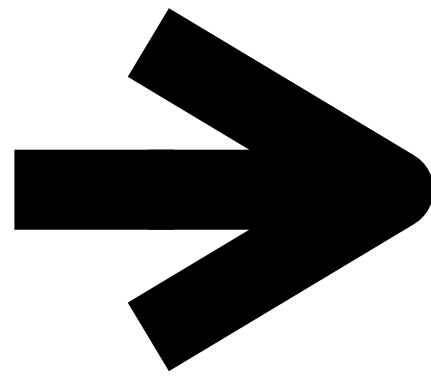
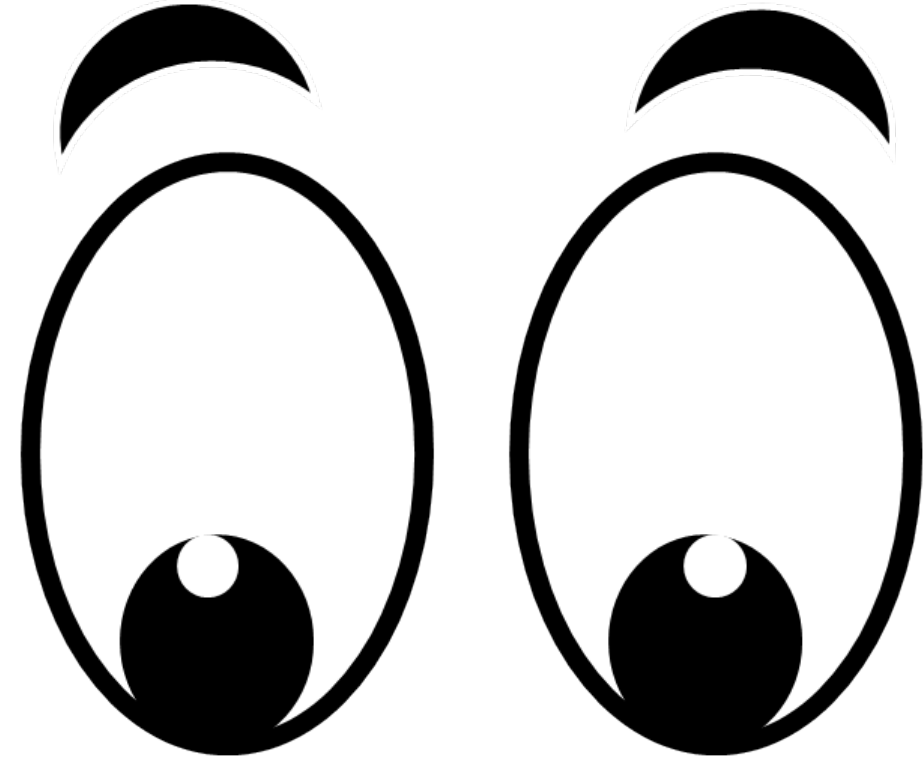



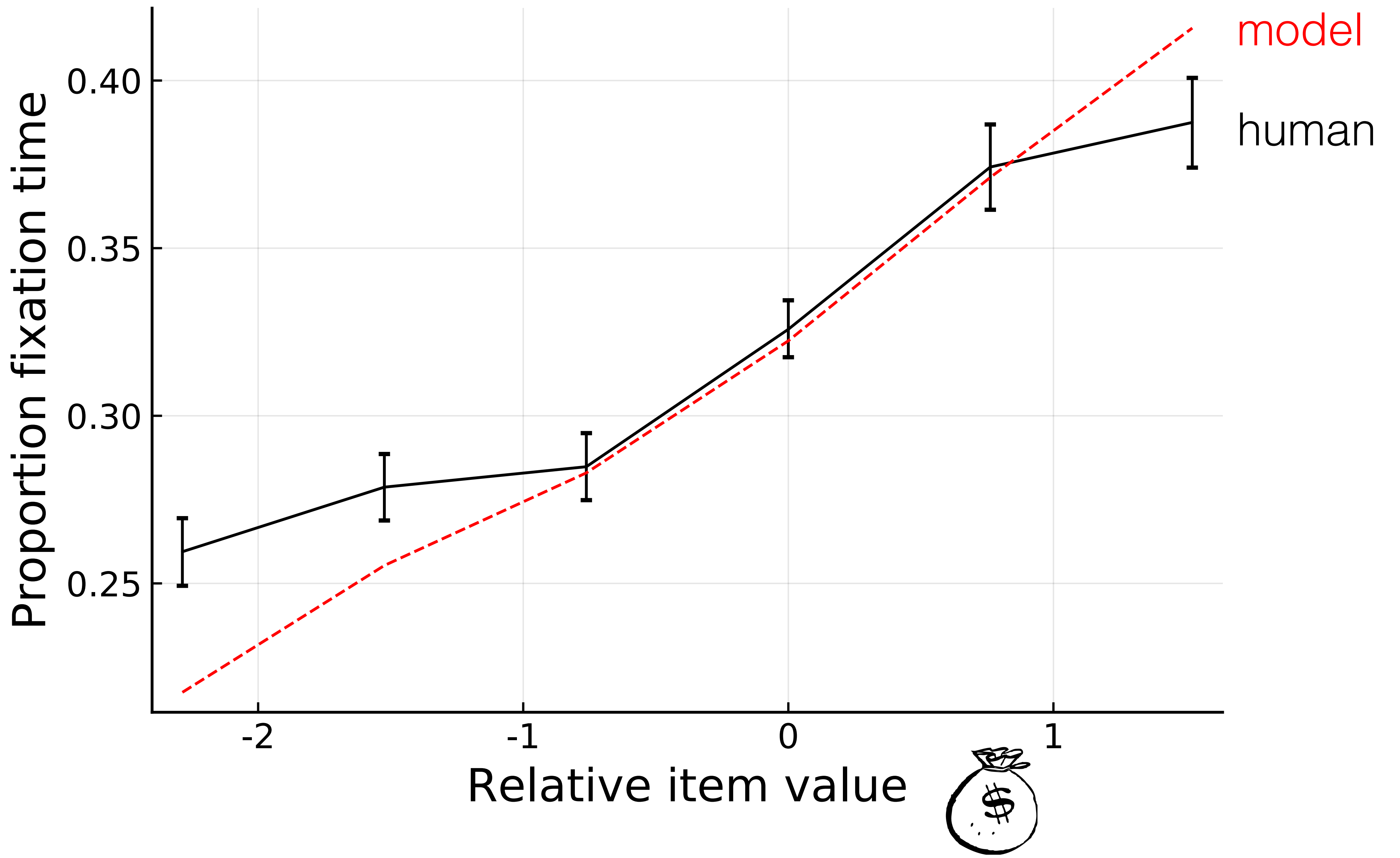
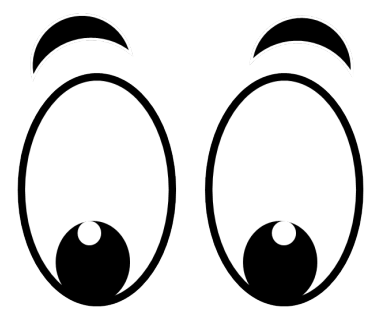

Relative item value



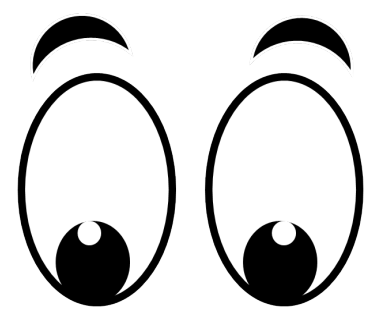

Probability of fixating  
on highest-value item

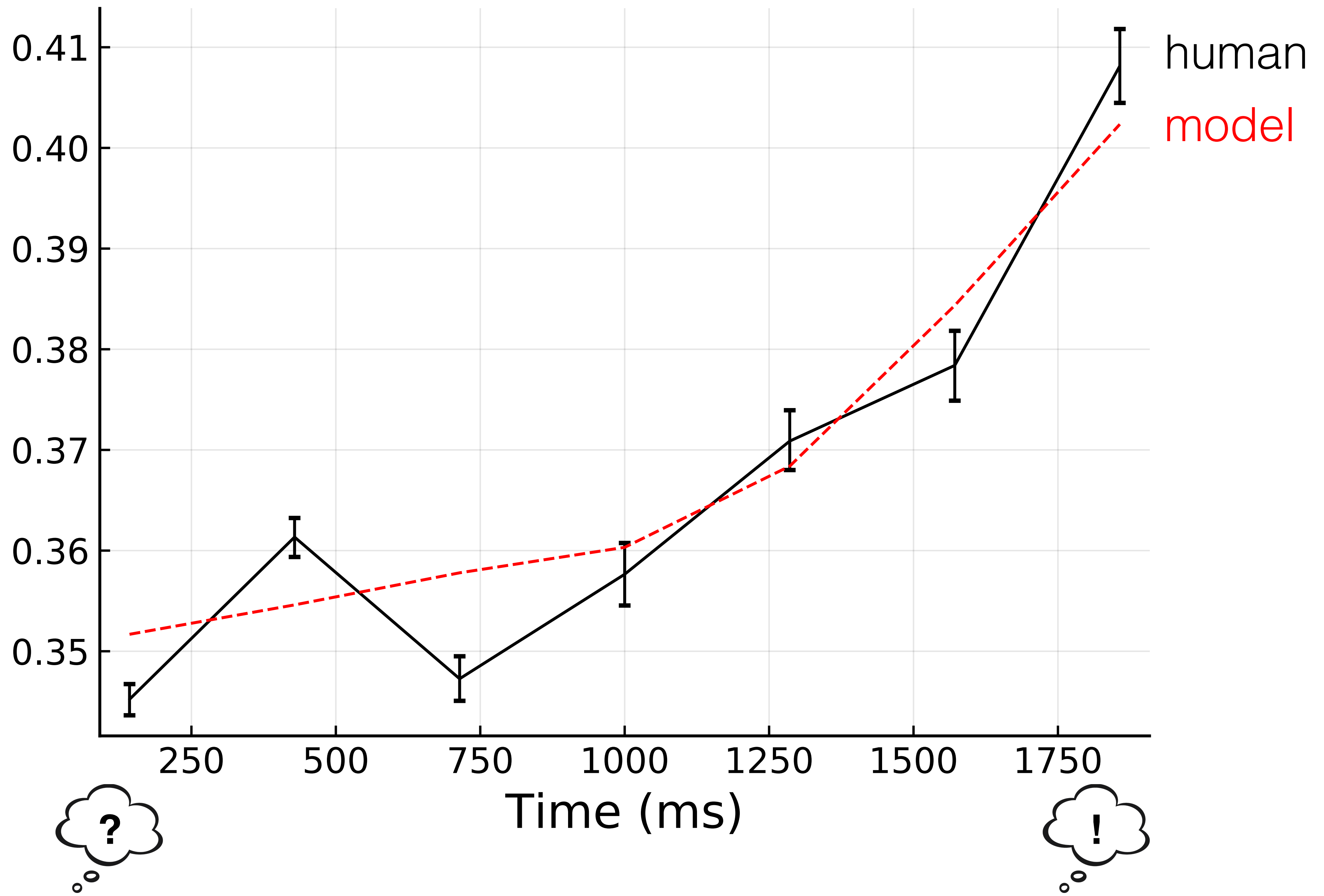

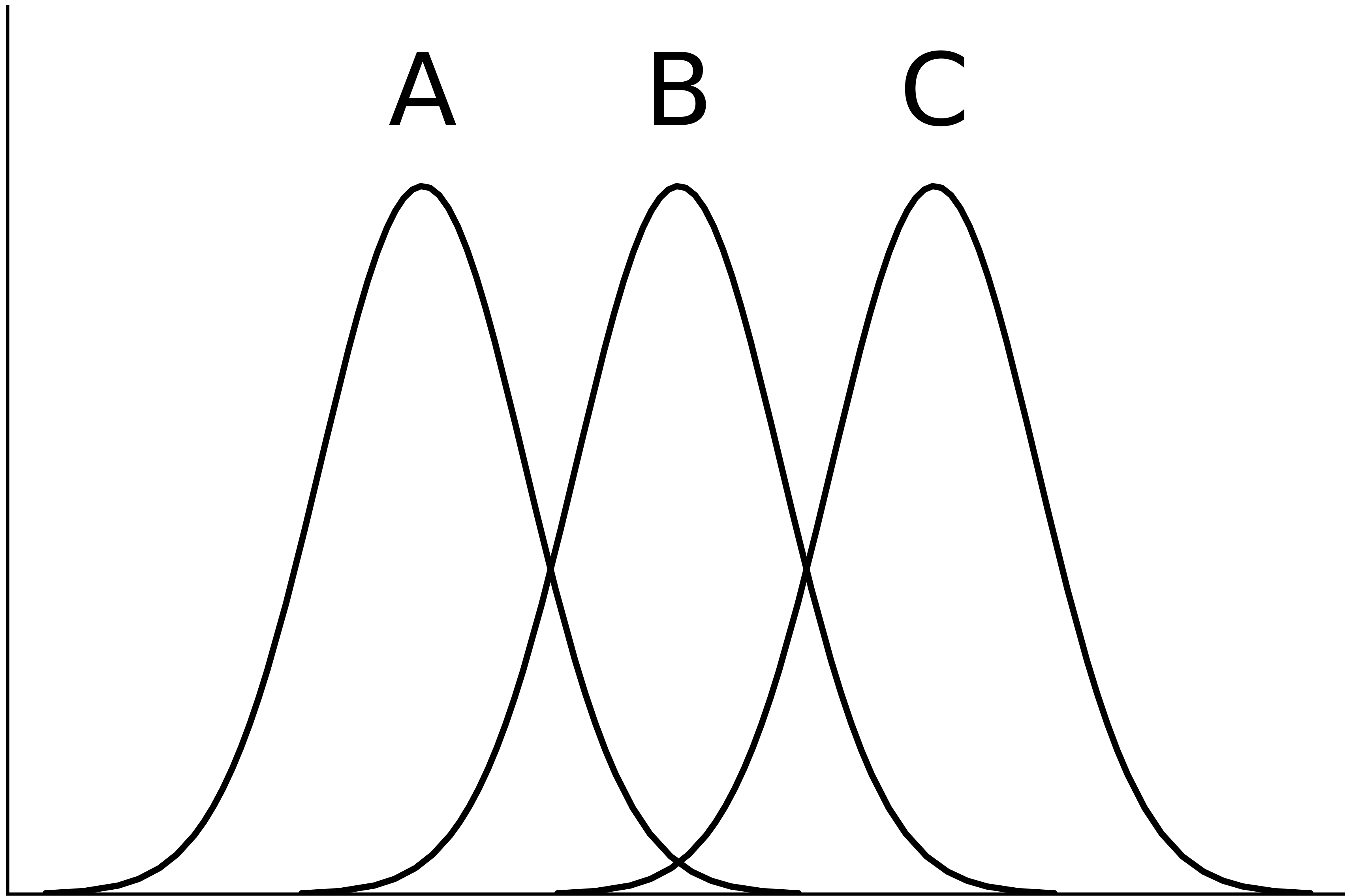

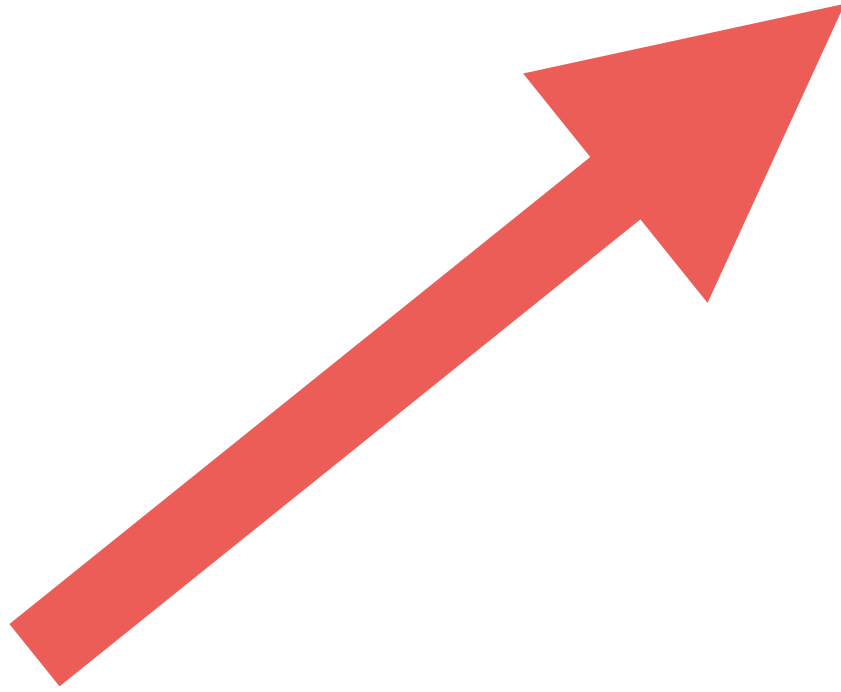
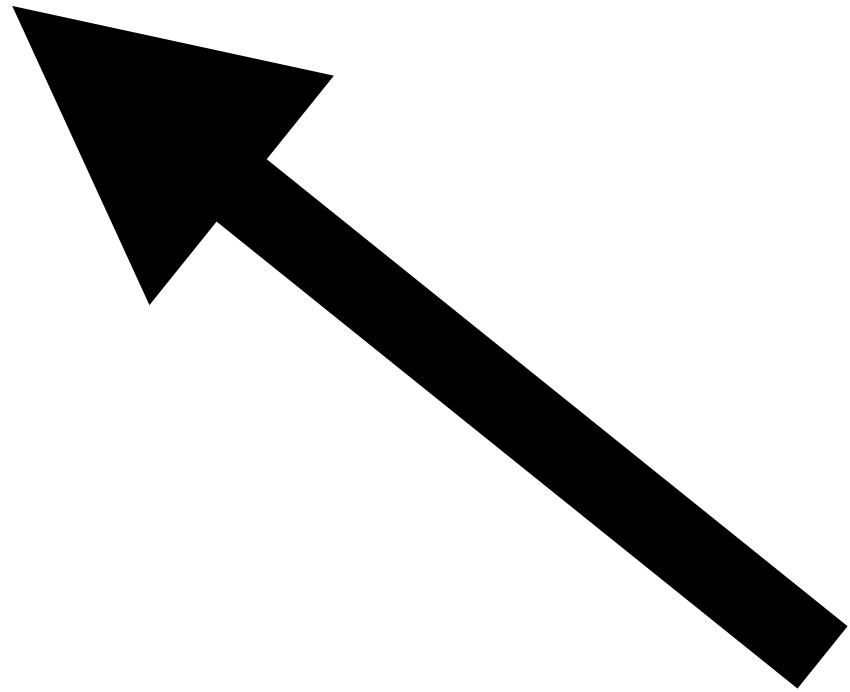
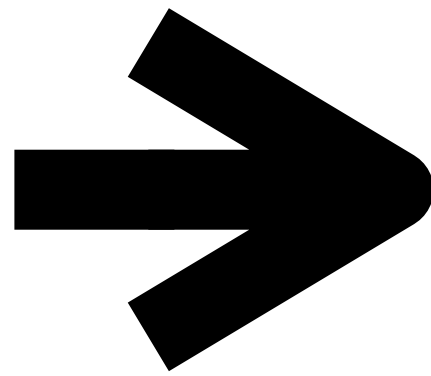
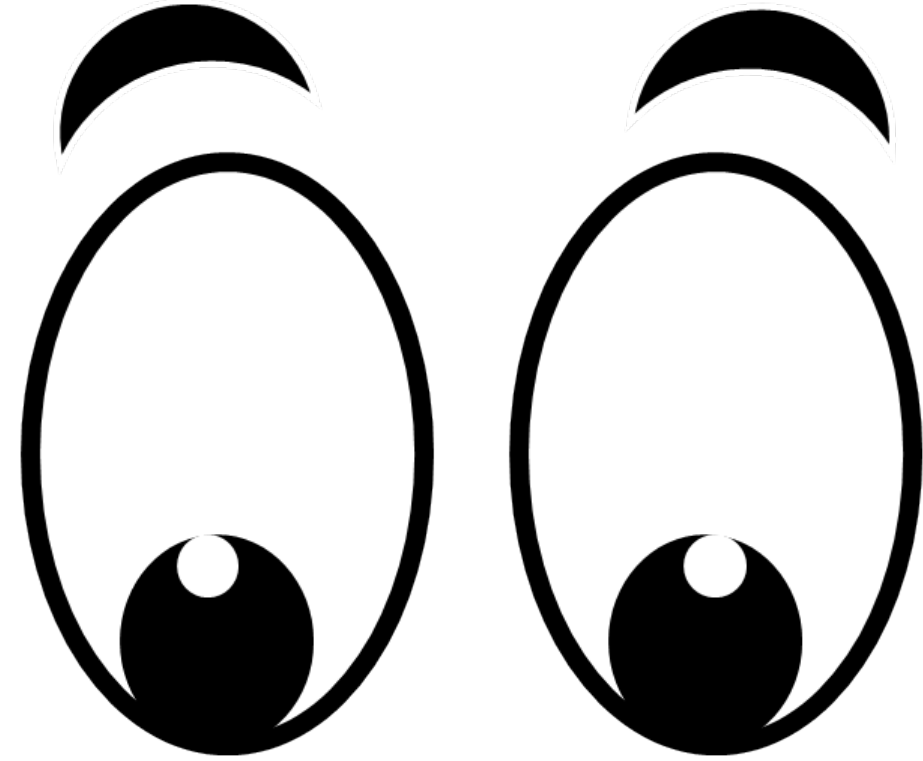

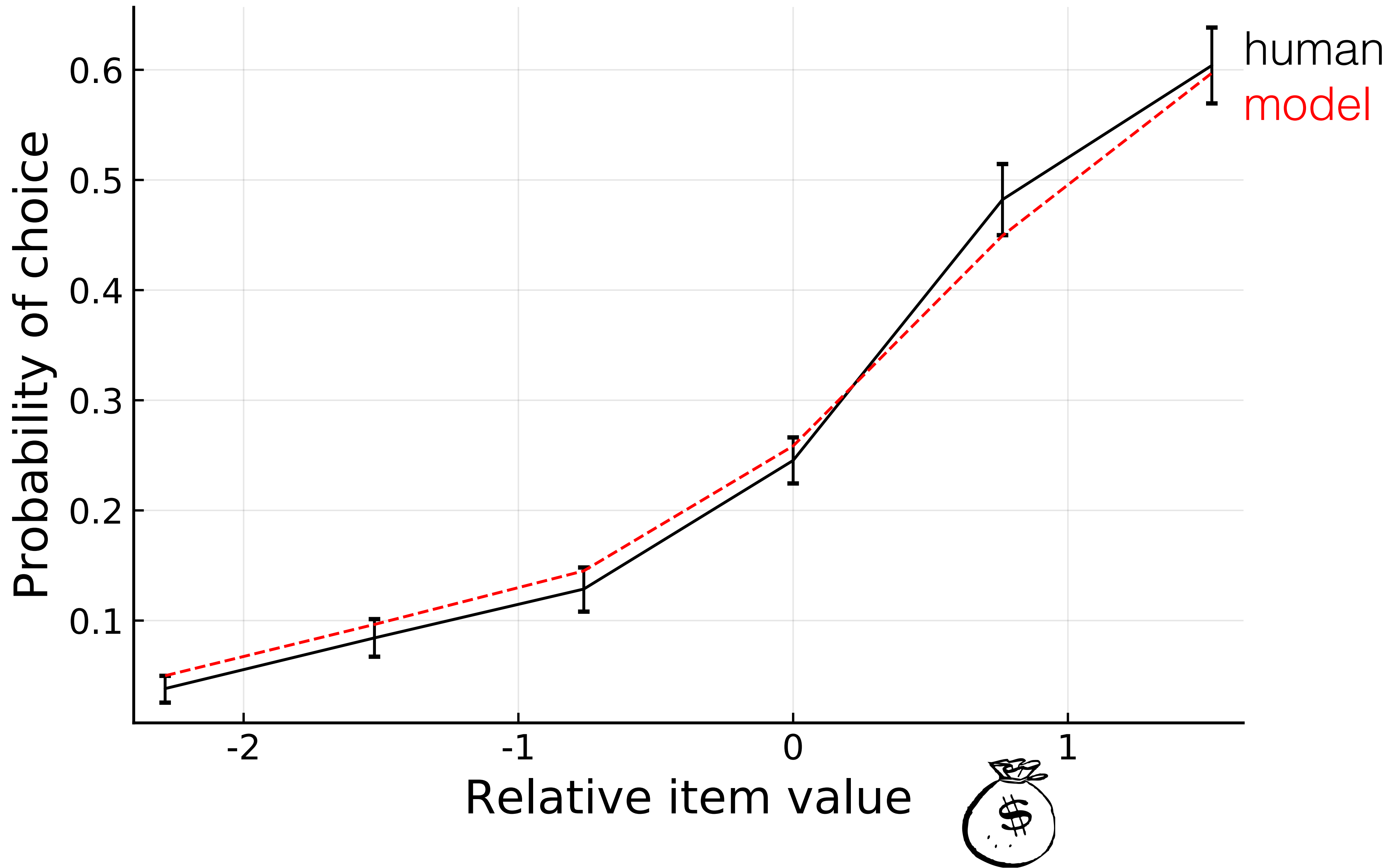

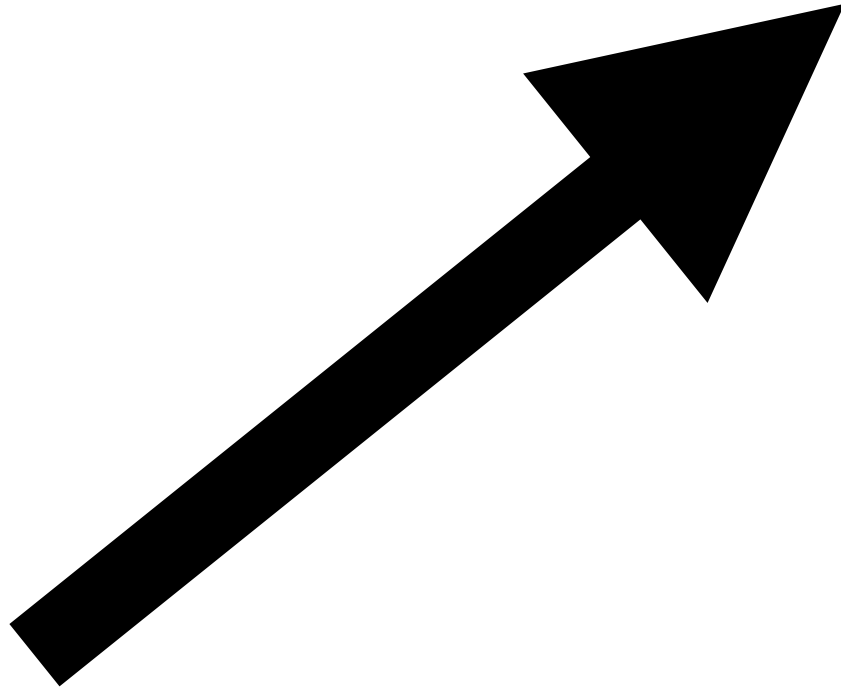
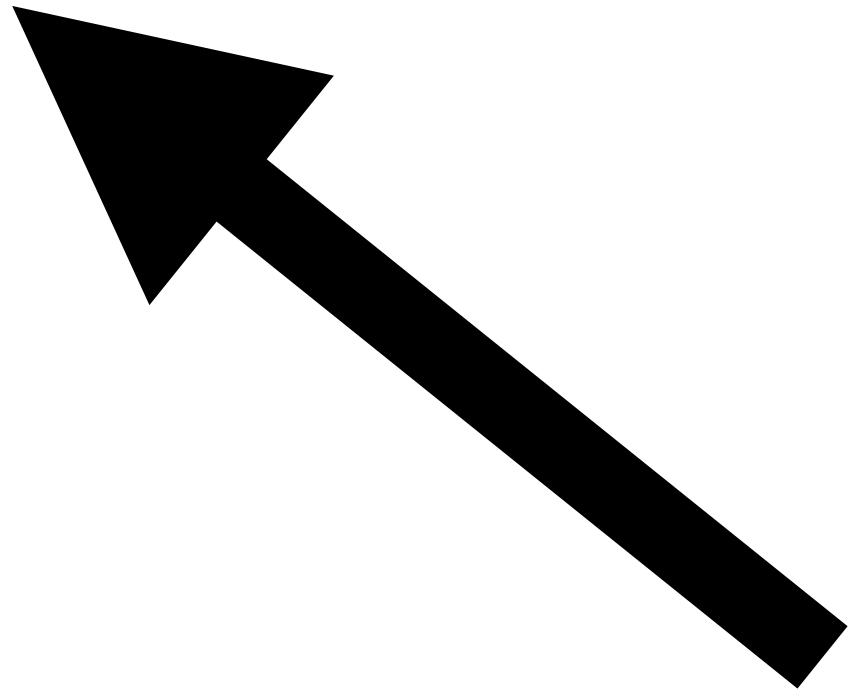
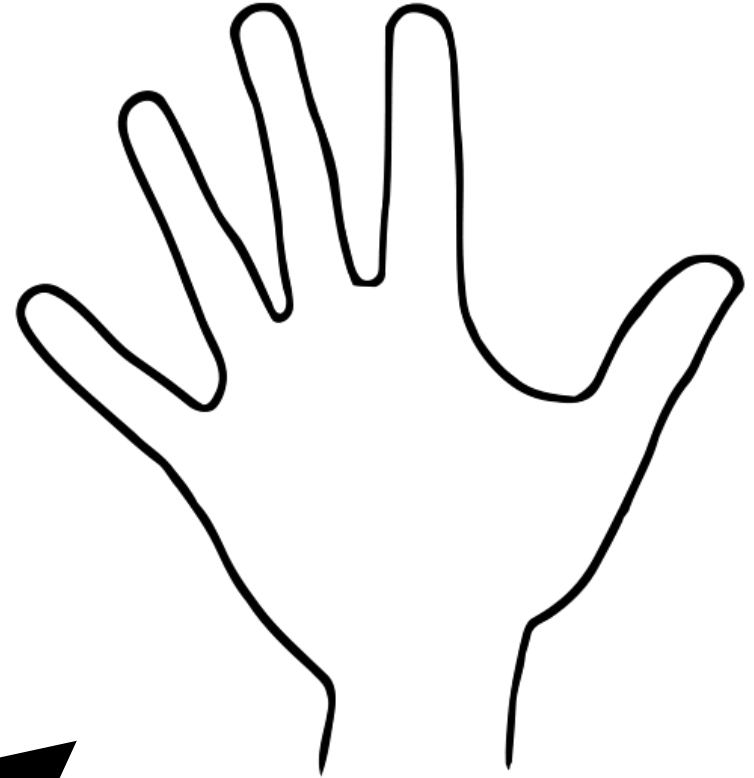
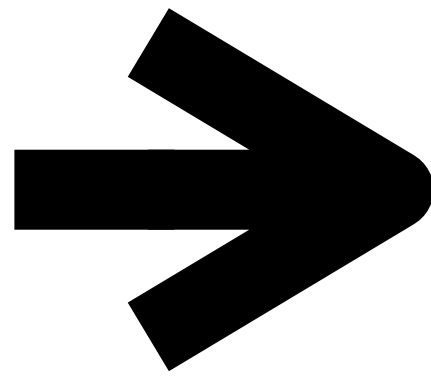
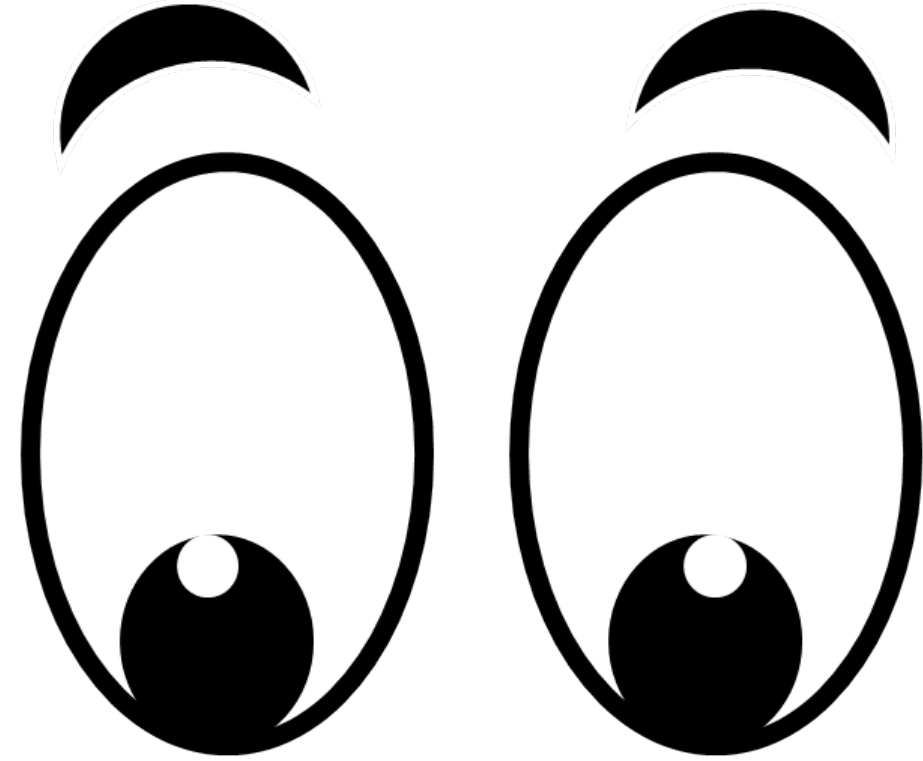

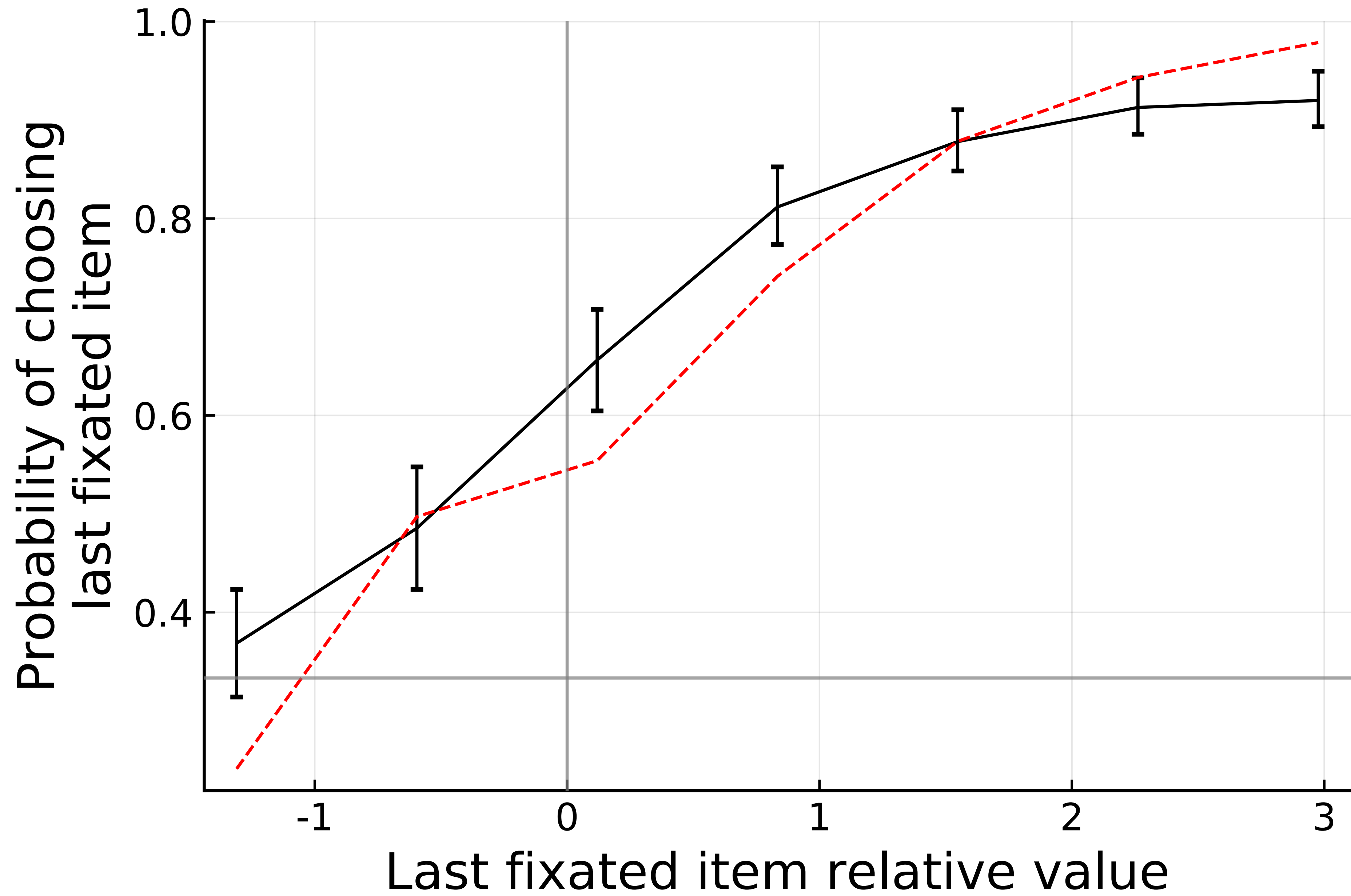

Looking forward



# Looking forward

## **Challenges**

- ▶ Computing a likelihood for parameter estimation.
- ▶ Explaining effects in the  $n = 2$  case.

# Looking forward

## Challenges

- ▶ Computing a likelihood for parameter estimation.
- ▶ Explaining effects in the  $n = 2$  case.

## Takeaways

- ▶ Some apparent “attentional biases” may actually be the result of the rational allocation of attention.
- ▶ Metalevel Markov decision processes provide a principled (and general) way to model cognitive processes in a rational framework.

Thanks!



Antonio Rangel



Tom Griffiths

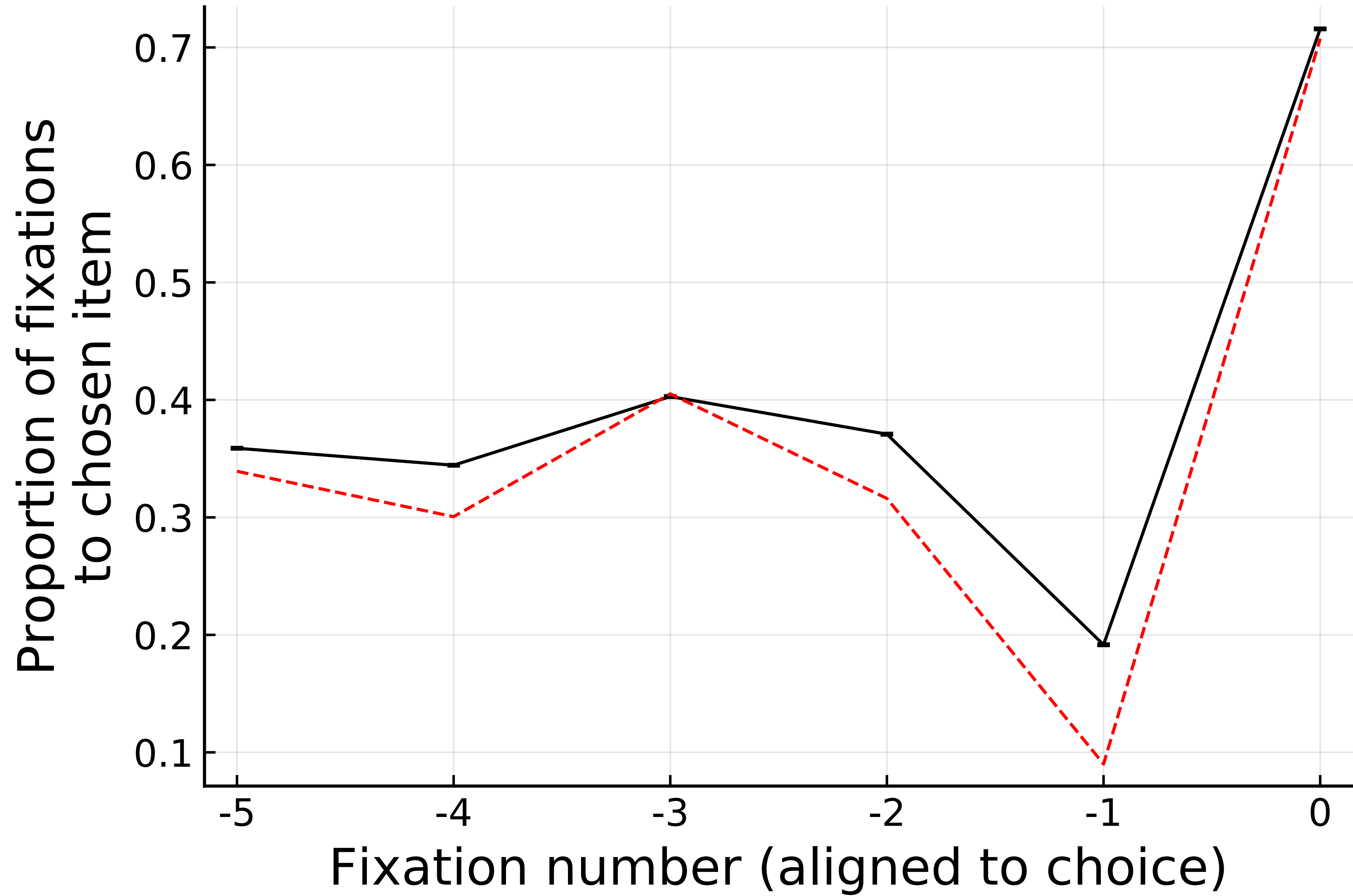

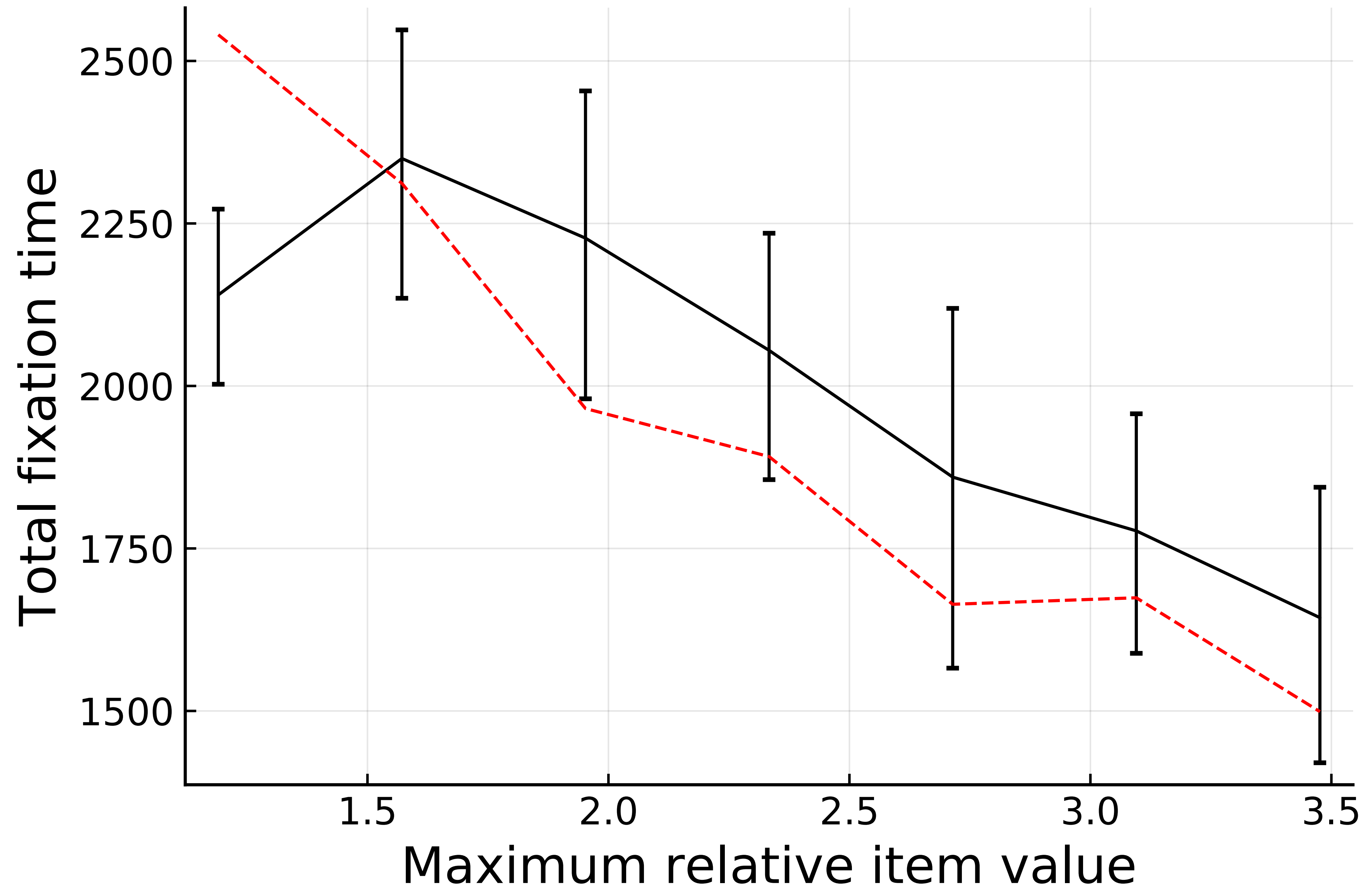

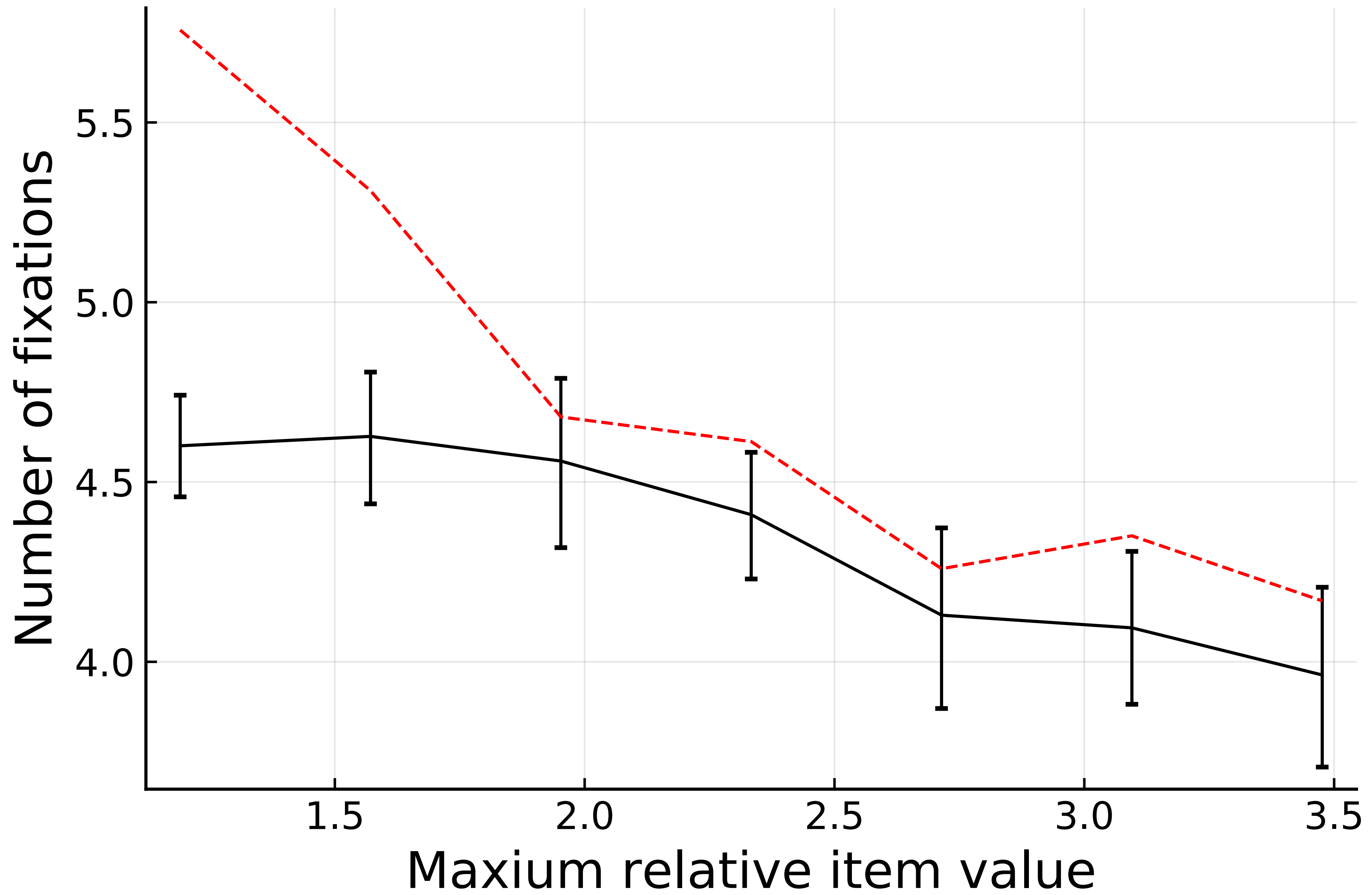

# Relation to drift diffusion models

## Similarities

- ▶ Decision variables represent the accumulation of evidence over time.
- ▶ Accumulators are subject to random walk dynamics.
- ▶ Predicts choices and reaction times.

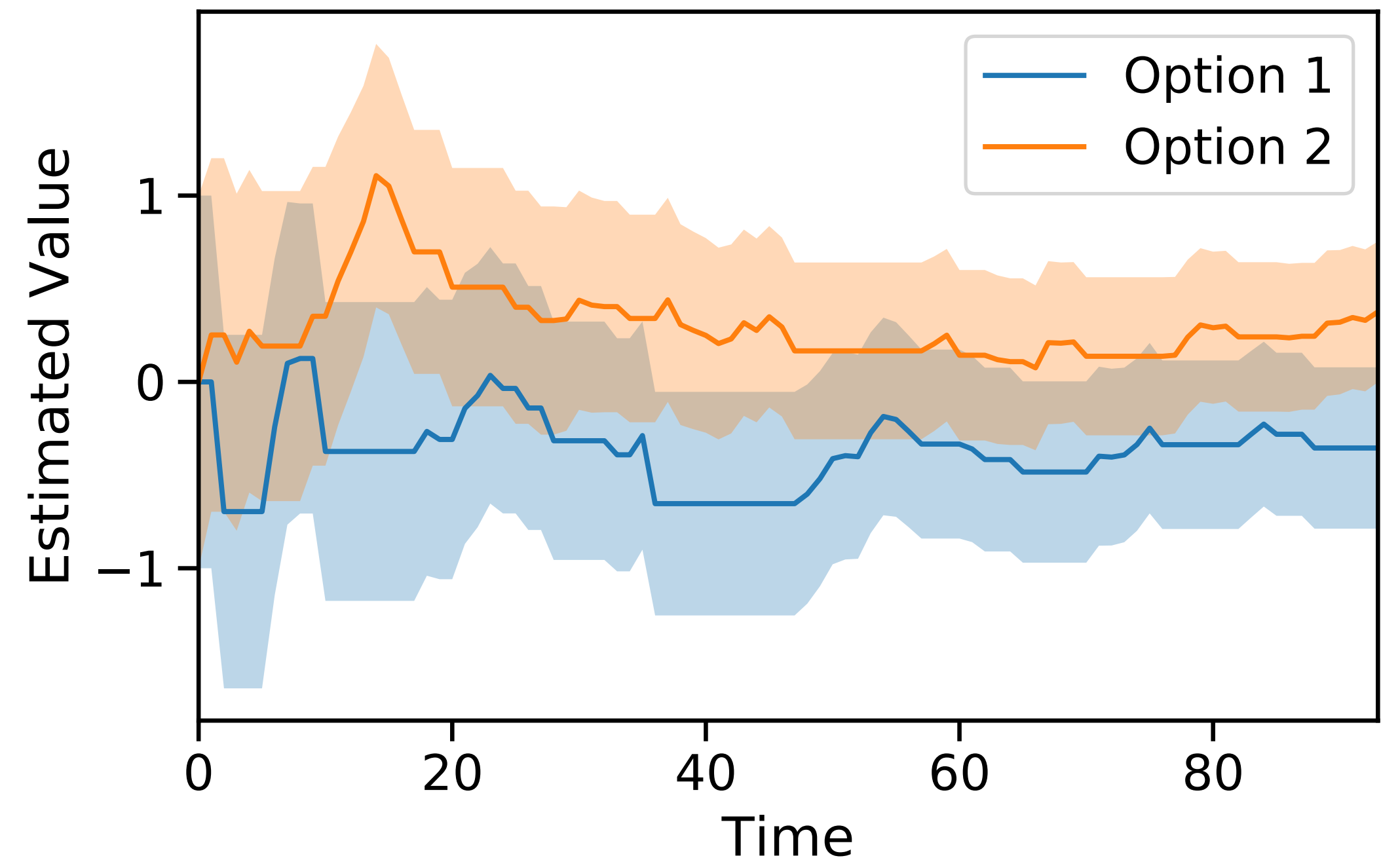

# Relation to drift diffusion models

## Differences

- ▶ Accumulator is a posterior distribution over value.
- ▶ The variance of the random walk is not constant across time.
- ▶ Decision rule based on expected value of computation.
- ▶ Predicts attention.

